

TOSHIBA

FILE NO. 140-200123

SERVICE MANUAL

VIDEO CASSETTE RECORDER

W425

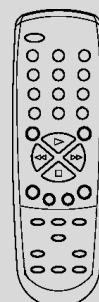
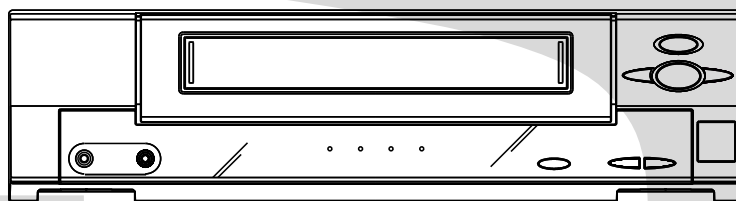

SERVICING NOTICES ON CHECKING

1. KEEP THE NOTICES

As for the places which need special attentions, they are indicated with the labels or seals on the cabinet, chassis and parts. Make sure to keep the indications and notices in the operation manual.

2. USE THE DESIGNATED PARTS

The parts in this equipment have the specific characters of incombustibility and withstand voltage for safety. Therefore, the part which is replaced should be used the part which has the same character.

Especially as to the important parts for safety which is indicated in the circuit diagram or the table of parts as a \triangle mark, the designated parts must be used.

3. PUT PARTS AND WIRES IN THE ORIGINAL POSITION AFTER ASSEMBLING OR WIRING

There are parts which use the insulation material such as a tube or tape for safety, or which are assembled in the condition that these do not contact with the printed board.

The inside wiring is designed not to get closer to the pyrogenic parts and high voltage parts. Therefore, put these parts in the original positions.

4. PERFORM A SAFETY CHECK AFTER SERVICING

Confirm that the screws, parts and wiring which were removed in order to service are put in the original positions, or whether there are the portions which are deteriorated around the serviced places serviced or not. Check the insulation between the antenna terminal or external metal and the AC cord plug blades. And be sure the safety of that.

HOW TO ORDER PARTS

Please include the following informations when you order parts. (Particularly the VERSION LETTER.)

1. MODEL NUMBER and VERSION LETTER

The MODEL NUMBER can be found on the back of each product and the VERSION LETTER can be found at the end of the SERIAL NUMBER.

2. PART NO. and DESCRIPTION

You can find it in your SERVICE MANUAL.

CONTENTS

SERVICING NOTICES ON CHECKING	A1-1
HOW TO ORDER PARTS	A1-1
CONTENTS	A2-1
GENERAL SPECIFICATIONS	A3-1-A3-5
DISASSEMBLY INSTRUCTIONS	
1. REMOVAL OF MECHANICAL PARTS AND P. C. BOARDS	B1-1
2. REMOVAL OF DECK PARTS	B2-1-B2-6
3. REMOVAL AND INSTALLATION OF FLAT PACKAGE IC	B3-1, B3-2
KEY TO ABBREVIATIONS	C1-1, C1-2
SERVICE MODE LIST	C2-1
PREVENTIVE CHECKS AND SERVICE INTERVALS	C3-1
SERVICING FIXTURES AND TOOLS	D1-1
PREPARATION FOR SERVICING	D1-1
MECHANICAL ADJUSTMENTS	D2-1-D2-4
ELECTRICAL ADJUSTMENTS	D3-1, D3-2
BLOCK DIAGRAMS	
Y/C/AUDIO/CCD/HEAD AMP	E-1, E-2
SYSTEM CONTROL/SERVO	E-3, E-4
TUNER	E-5, E-6
OPERATION/POWER	E-7, E-8
PRINTED CIRCUIT BOARDS	
SYSCON/OPERATION	F-1-F-4
SCHEMATIC DIAGRAMS	
Y/C/AUDIO/CCD/HEAD AMP	G-1, G-2
SYSTEM CONTROL/SERVO	G-3, G-4
POWER	G-5, G-6
OPERATION	G-7, G-8
TUNER	G-9, G-10
INTERCONNECTION DIAGRAM	G-11, G-12
WAVEFORMS	H-1
MECHANICAL EXPLODED VIEW	I1-1
CHASSIS EXPLODED VIEWS	I2-1, I2-2
MECHANICAL REPLACEMENT PARTS LIST	J1-1
CHASSIS REPLACEMENT PARTS LIST	J2-1, J2-2
ELECTRICAL REPLACEMENT PARTS LIST	J3-1, J3-2

GENERAL SPECIFICATIONS

G-1	VCR System	System	VHS Player / Recorder			
		Video System	NTSC			
		Hi-Fi STEREO	No			
		NTSC PB(PAL60Hz)	No			
		Deck	DECK Loading System Motor	OVD-7 Front 3		
		Heads	Video Head	4Head		
			FM Audio Head	No		
			Normal Audio /Control	Mono / Yes		
			Erase(Full Track Erase)	Yes		
		Tape Speed	Rec PAL NTSC	- SP/SLP		
			Play PAL NTSC	- SP/LP/SLP		
		Fast Forward / Rewind Time (Approx.)	with Cassette	FF:4'50"/REW:2'30" T-120		
		Forward/Reverse	NTSC or PAL-M	SP/LP/SLP=3x,5x/7x,9x/9x,15x		
		Picture Search	PAL or SECAM	-		
		Frame Advance		1/10		
Slow Speed		1/10				
G-2	Tuning System	Broadcasting System	US System M			
		Tuner and Receive CH	System Destination Tuning System Input Impedance CH Coverage	1Tuner USA(w/CATV) F-Synth VHF/UHF 75 OHM 2-69,4A,A-5- A-1,A~I, J~ W W+1~W+84		
		Intermediate Frequency	Picture(FP) Sound(FS) FP-FS	45.75MHz 41.25MHz 4.50MHz		
		Preset CH		No		
		RF Converter Output		Yes		
			Channel	3 or 4 ch		
			Level/Impedance	66dBu /75ohm		
			Sound Selector	No		
			Stereo/Dual TV Sound	No		
		G-3	Power	Power Source	AC DC	120V,60Hz -
				Power Consumption	Power On(at AC) Stand by (at AC) Per Year	8W at 120V 60Hz 1.8W at 120V 60Hz - kWh/Year
Protector	Power Fuse Dew Sensor			Yes No		
G-4	Regulation	Safety Radiation	UL FCC			
G-5	Temperature	Operation Storage	5oC - 40oC -20oC - 60oC			
G-6	Operating Humidity		Less then 80% RH			
G-7	Signal	Video Signal	Input Level Output Level S/N Ratio (Weighted) Horizontal Resolution at SP Mode	1 V p-p/75 ohm 1 V p-p/75 ohm 50 230Line		
		Audio Signal (0dB=0.775Vrms)	Input Level Output Level S/N Ratio at SP (Weighted) Harmonic Distortion (1KHz) Frequency Response	-8dBm/50Kohm -8dBm/1Kohm 42dB 1.5% at SP 100Hz - 10kHz at LP 100Hz - 6kHz at SLP 100Hz - 4kHz		
		Hi-Fi Audio Signal	Dynamic Range : More than Frequency Response Wow And Flutter : Less than Channel Separation : More than Harmonic Distortion : Less than	- - - - -		

GENERAL SPECIFICATIONS

G-8	On Screen Display	Menu	Yes
		Menu Type	Character
		ATS	No
		Timer Rec Set	Yes
		Auto Repeat On/Off	Yes
		SAP On Off	No
		CH Set-Up	Yes
		TV/CATV	Yes
		Auto CH Memory	Yes
		Add/Delete	Yes
		Pin Code Registration	No
		System Set-Up	No
		Clock Set	Yes (Calendar 12H)
		Language	Yes
		No Noise Back Ground	Yes
		G-CODE(or SHOWVIEW or PLUSCODE)No. Entry	No
		NICAM 1/2,NICAM Off,Audio Output	No
		Stereo,Audio Output,SAP	No
		Play/Stop/FF/Rew/Rec/OTR/T-Rec/Pause/Eject/Tape In (Symbol Mark)	Yes
		CH/AV	Yes
		Clock	Yes
		Repeat	Yes
		Pin Code	No
		Tape Counter	Yes
		Index	No
		Hotel Lock	No
		Tape Speed	Yes
ATR/Manual Tracking	Yes		
Hi-Fi	No		
S-Repeat/SR-R/SR-Play	No		
VPS	No		
PDC	No		
G-9	OSD Language	English French Spanish	
G-10	Clock,Timer and Timer Back-up	Calendar	1990/1/1 ~ 2081/12/31
		Timer Events	8 prog/1 month
		One Touch Recording Max Time	5 Hours
		OTPB Valid Time	No
		Timer Back-up (at Power Off Mode)	5 sec.
G-11	Display	Indicator	No
		Indicator Type	-
		Clock/Counter,CH,Timer Rec,OTR, Play Rec,FF(Cue).Rew(Rev).Stop.ATR	-
		Pause	-
		Still	-
		Eject(Tape Mark Flash)	-
		Slow	-
		WKL,Y.M.D,Start,End	-
		AFT	-
		Repeat	-
		A-DUB	-
		VCR	-
		Memory	-
		Index	-
		VPS	-
		PDC	-
		SP	-
		LP	-
		SLP	-
		AM	-
		PM	-
F1,F2	-		
RF Output CH	-		
Tape In	-		

GENERAL SPECIFICATIONS

G-12	Remote Control	Unit	RC-EA	
		Glow in Dark Remocon	No	
		Power Source	Voltage(D.C) UM size x pcs	3V UM-4 x 2 pcs
		Total Keys		32 Keys
		Keys	Power	Yes
			1	Yes
			2	Yes
			3	Yes
			4	Yes
			5	Yes
			6	Yes
			7	Yes
			8	Yes
			9	Yes
			0	Yes
			CH Up	Yes
			CH Down	Yes
			Input Select	Yes
			Play	Yes
			F.Fwd	Yes
			Rew	Yes
			Pause/Still	Yes
			Stop	Yes
			Rec/OTR	Yes
			Eject	No
			Counter Reset	Yes
			Speed	Yes
			Timer Rec	Yes
			TV Monitor	No
			Quick View	No
			Program	No
			Slow	Yes
			Auto Tracking	Yes
Set/Tracking+	Yes			
Set/ Tracking -	Yes			
Menu	Yes			
Enter	Yes			
Cancel	Yes			
Call	Yes			
TV/VCR	Yes			
Sleep Timer	No			
Muting	No			
Clock/Counter	No			
Zero Return	No			
CM Skip	No			
Audio Select	No			
G-13	Features	Auto Head Cleaning	No	
		Auto Tracking	Yes	
		Index Search	No	
		HQ (VHS Standard High Quality)	Yes	
		Auto Power On, Auto Play, Auto Rewind, Auto Eject	Yes	
		Auto Power Off	Yes	
		Forward/Reverse Picture Search	Yes	
		VIDEO PLUS+(SHOWVIEW,G-CODE)	No	
		ATS	No	
		PDC	No	
		VPS	No	
		One Touch Playback	No	
		Picture Control	No	
		Auto CH Memory	Yes	
		Channel Lock	No	
		Auto Clock	No	
		Anti Theft	No	
		Audio Dubbing	No	
		Remort Control Code 1/2	No	
		SQPB	Yes	
CATV	Yes			
Energy Star	Yes			
MTS(SAP)	No			
CM Skip(30sec x 6 Times)	No			

GENERAL SPECIFICATIONS

G-14	Accessories	Owner's Manual	Language	English	
			w/Guarantee Card	Yes	
		Remote Control Unit		Yes	
		Dew Cation Sheet		No	
		Video Cassette Tape		No	
		Battery	UM size x pcs	Yes UM 4 x 2 pcs	
		Security Tag		Yes	
		Toll Free Insert Sheet		No	
		Quick Set-Up Sheet		No	
		Information Sheet (Buyer Supply)		No	
		75 Ohm Coaxial Cable		Yes(Single shield)	
		Rod Antenna		No	
			Poles		
			Terminal		
		Loop Antenna		No	
			Terminal		
		U/V Mixer		No	
		DC Car Cord (Center+)		No	
		Guarantee Card		No	
		Warning Sheet		No	
		Circuit Diagram		No	
		Antenna Change Plug		No	
		Service Facility List		No	
		Important Safeguard		No	
		Dew/AHC Caution Sheet		No	
		AC Plug Adapter		No	
		Quick Set-up Sheet		No	
		AC Cord		No	
AV Cord		No			
Registration Card		Yes			
E.S.P. Sheet		Yes			
Tape Rewinder(Buyer Supply)		No			
300 ohm to 75 ohm Antenna Adapter		No			
G-15	Interface	Switch	Front	Power	Yes
				Play	Yes
				Pause/Still	No
				System Select	No
				One Touch Playback	No
				Channel Up	Yes
				Channel Down	Yes
				F.FWD/Cue	Yes
				Eject/Stop	Yes
				Main Power SW	No
				Volume Up	No
				Volume Down	No
				Rew/Rev	Yes
				Rec/OTR	Yes
			Rear	RF Output SW	No
		Indicator		Power	Yes(RED)
				Stand by	No
				Rec/OTR	No
				Repeat	No
				TV/VCR	Yes(RED)
				Rec	Yes(RED)
				T-Rec	Yes(RED)
				Tape In	No
		Terminals	Front	Video Input	RCA x 1
				Audio Input	RCA x 1
				Other Terminal	No
			Rear	Video Input	RCA x 1
				Audio Input	RCA x 1
		Video Output	RCA x 1		
		Audio Output	RCA x 1		
		Euro Scart	No		
		DC Jack 12V(Center +)	No		
		VHF/UHF Antenna Input/Output	F Type		
		AC Inlet	No		
G-16	Set Size	Approx. W x D x H (mm)	360 x 229 x 95		
G-17	Weight	Net (Approx.)	3.2kg(7.1lbs)		
		Gross (Approx.)	3.8kg(8.4lbs)		

GENERAL SPECIFICATIONS

G-18	Carton	Master Carton	No	
		Content	-	
		Material	-	
		Dimensions W x D x H(mm)	-	
		Description of Origin	-	
		Gift Box	Yes	
		Material	Single/Full Color	
		Dimensions W x D x H(mm)	420x291x160	
		Design	As Per BUYER 's	
		Description of Origin	Yes	
		Drop Test	Natural Dropping At	1Corner / 3Edges / 6Surfaces
			Height (cm)	80
	Container Stuffing(40' container)	3,136Sets		
G-19	Cabinet Material	Cabinet Front	PS 94V2 DECABROM	

DISASSEMBLY INSTRUCTIONS

1. REMOVAL OF MECHANICAL PARTS AND P.C. BOARDS

1-1: TOP CABINET, FRONT CABINET AND OPERATION PCB (Refer to Fig. 1-1)

1. Remove the 4 screws ①.
2. Remove the Top Cabinet in the direction of arrow (A).
3. Disconnect the following connector: (CP651).
4. Unlock the 7 supports ②.
5. Remove the Front Cabinet in the direction of arrow (B).
6. Remove the 4 screws ③ and remove the Operation PCB.

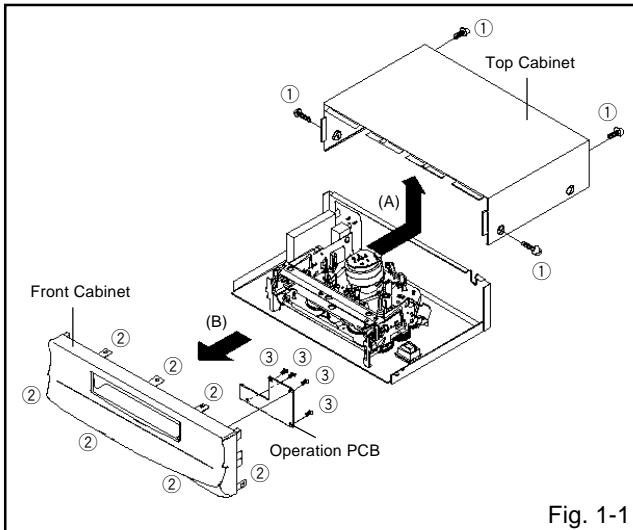

1-2: FLAP (Refer to Fig. 1-2)

1. Open Flap to 90° and flex in direction of arrow (A), at the same time slide in direction of arrow (B).
2. Then lift in direction of arrow (C).

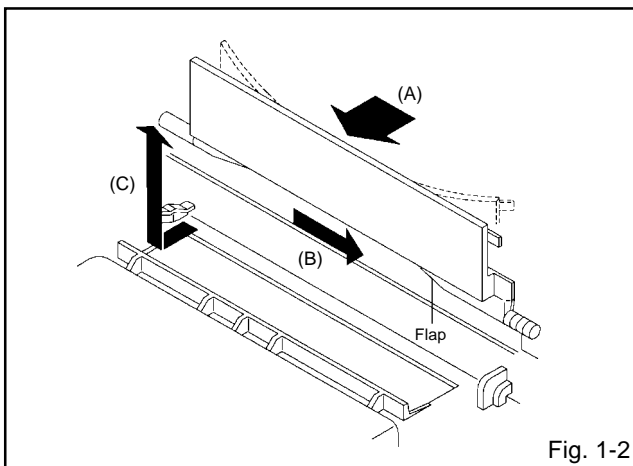

1-3: DECK CHASSIS (Refer to Fig. 1-3)

1. Remove the 3 screws ①.
2. Disconnect the following connectors: (CP1001, CP4001, CP4002 and CP4003).
3. Remove the Deck Chassis in the direction of arrow.

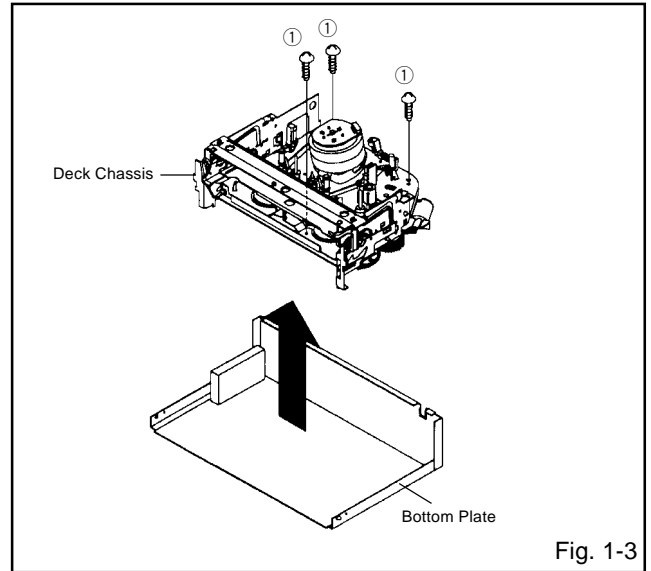

1-4: SYSCON PCB (Refer to Fig. 1-4)

1. Remove the 2 screws ①.
2. Remove the screw ②.
3. Remove the Syscon PCB in the direction of arrow.

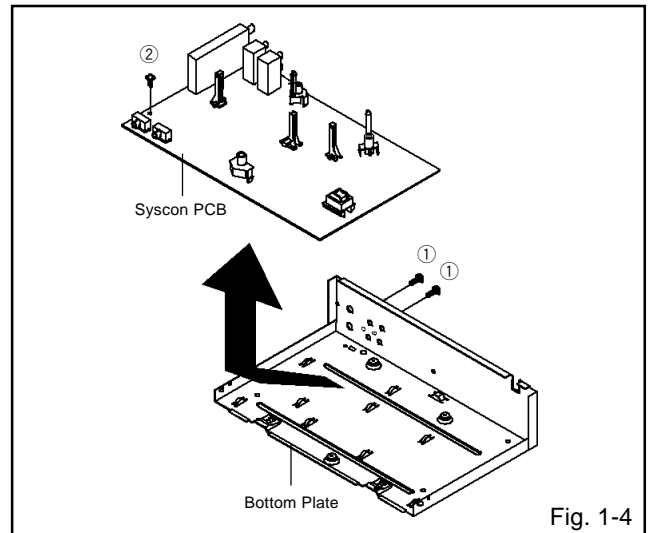

DISASSEMBLY INSTRUCTIONS

2. REMOVAL OF DECK PARTS

2-1: TOP BRACKET (Refer to Fig. 2-1)

1. Extend the 2 supports ①.
2. Slide the 2 supports ② and remove the Top Bracket.

NOTE

1. After the installation of the Top Bracket, bend the support ① so that the Top Bracket is fixed.

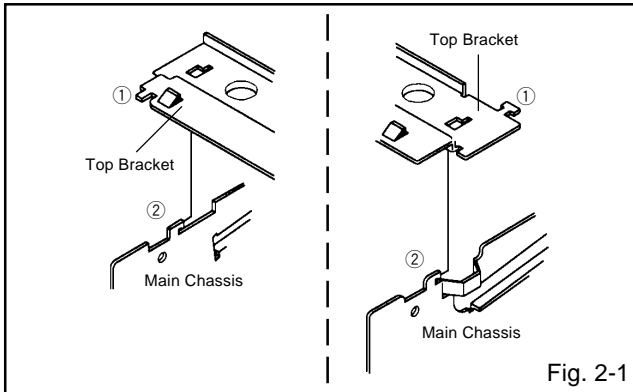

Fig. 2-1

2-2: CASSETTE HOLDER ASS'Y (Refer to Fig. 2-2)

1. Move the Cassette Holder Ass'y to the front side.
2. Push the Locker R to remove the Cassette Side R.
3. Remove the Cassette Side L.

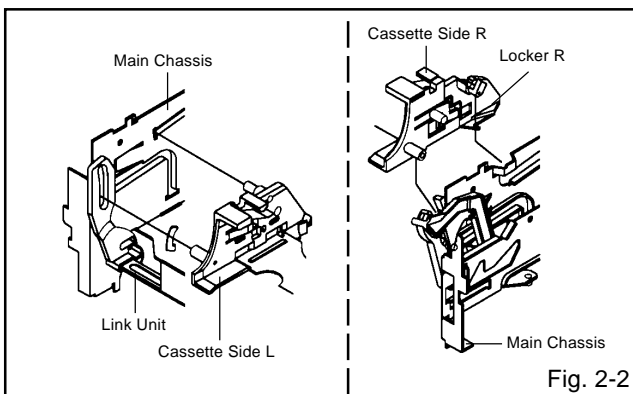

Fig. 2-2

2-3: CASSETTE SIDE L/R (Refer to Fig. 2-3-A)

1. Remove the Locker Spring.
2. Unlock the 4 supports ① and then remove the Cassette Side L/R.
3. Unlock the support ② and then remove the Locker R.

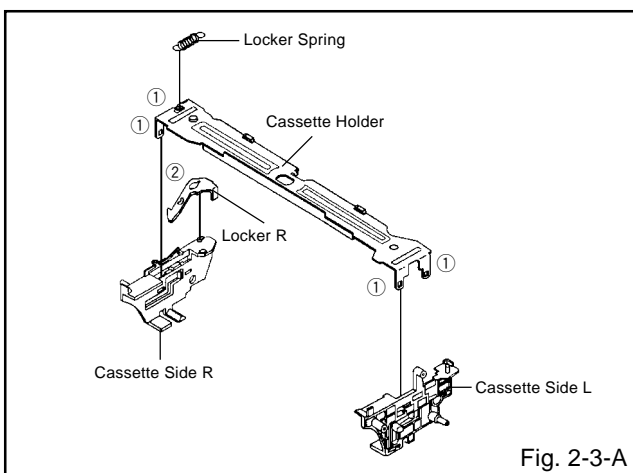

Fig. 2-3-A

NOTE

1. In case of the Locker R installation, check if the two positions of Fig.2-3-B are correctly locked.
2. When you install the Cassette Side R, be sure to move the Locker R after installing.

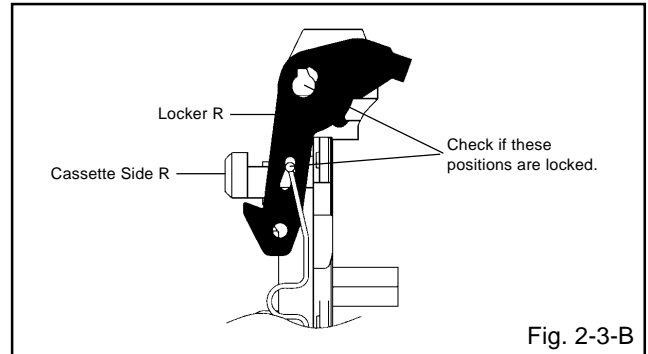

Fig. 2-3-B

2-4: LINK UNIT (Refer to Fig. 2-4)

1. Set the Link Unit to the Eject position.
2. Unlock the support ①.
3. Remove the (A) side of the Link Unit first, then remove the (B) side.

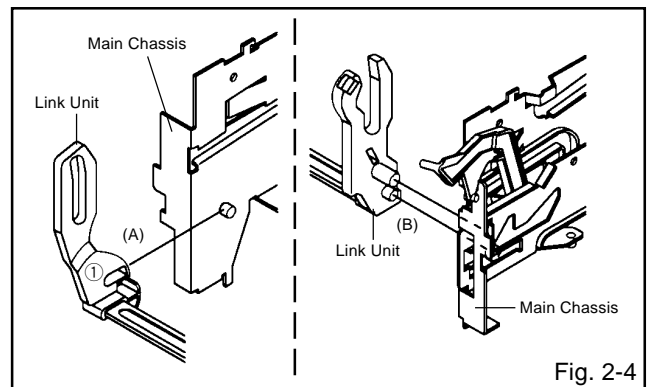

Fig. 2-4

2-5: LINK LEVER/FLAP LEVER (Refer to Fig. 2-5)

1. Extend the support ①.
2. Remove the Link Lever.
3. Remove the Flap Lever.

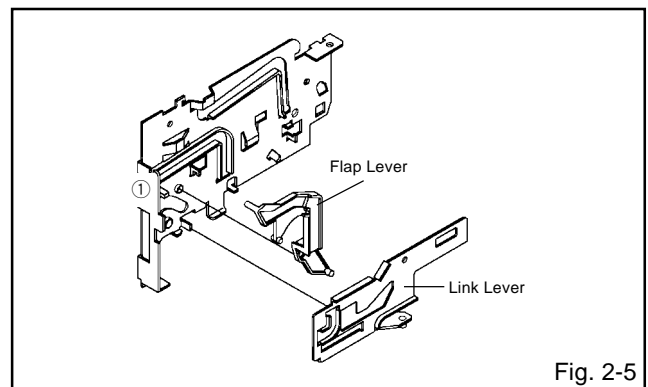
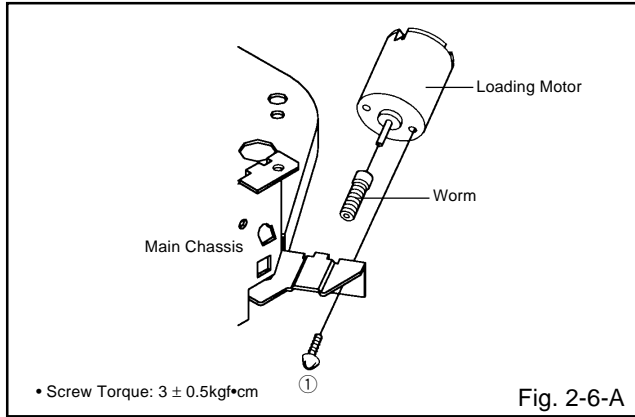

Fig. 2-5

DISASSEMBLY INSTRUCTIONS

2-6: LOADING MOTOR/WORM (Refer to Fig. 2-6-A)

1. Remove the screw ①.
2. Remove the Loading Motor.
3. Remove the Worm.



NOTE

1. In case of the Worm installation, check if the value of the Fig. 2-6-B is correct.
2. In case of the Loading Motor installation, hook the wire on the Cassette Opener as shown Fig. 2-6-C.

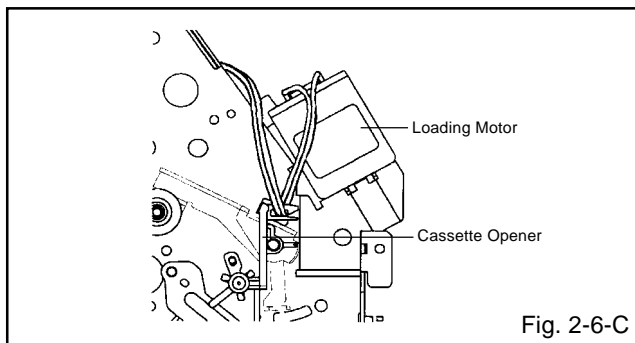
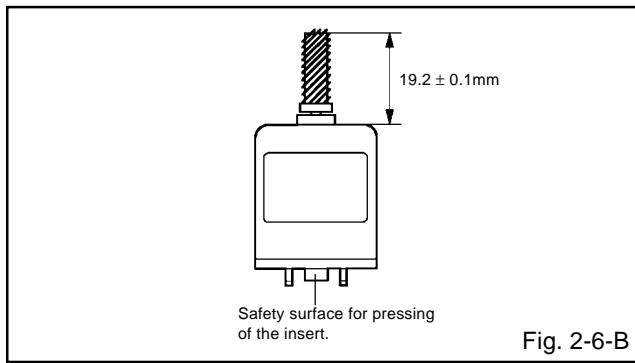

2-7: TENSION ASS'Y (Refer to Fig. 2-7-B)

1. Turn the Pinch Roller Cam clockwise so that the Tension Holder hook is set to the position of Fig. 2-7-A to move the Tension Arm Ass'y.
2. Remove the Tension Spring.
3. Unlock the 2 supports ① and remove the Tension Band.
4. Unlock the support ② and remove the Tension Arm Ass'y.
5. Unlock the support ③ and remove the Tension Connect.
6. Float the hook ④ and turn it clockwise then remove the Tension Holder.

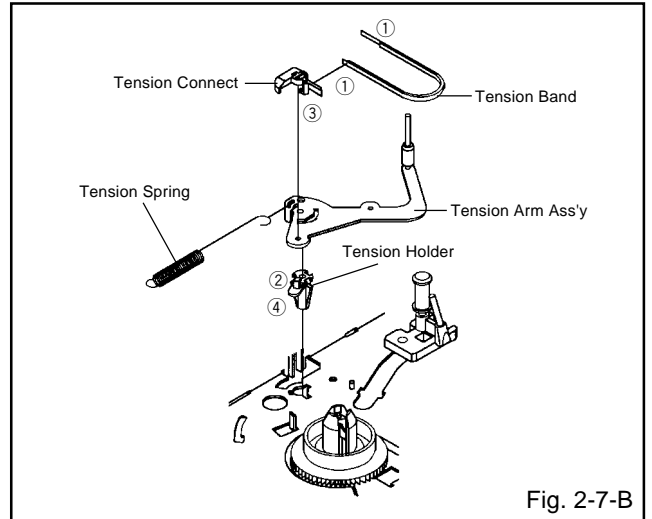
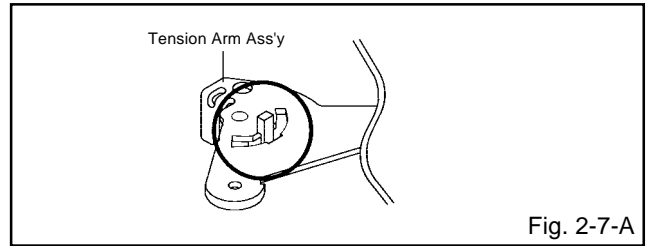

NOTE

1. In case of the Tension Band installation, note the direction of the installation. (Refer to Fig. 2-7-C)
2. In case of the Tension Band installation, install correctly as Fig. 2-7-D.
3. In case of the Tension Connect installation, install as the circled section of Fig. 2-7-E.

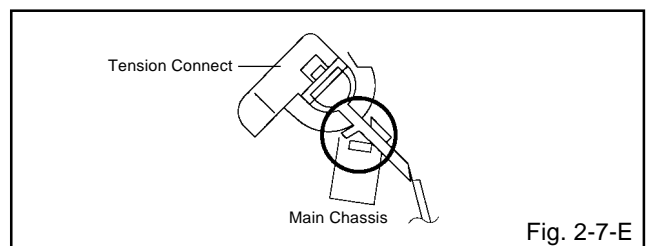
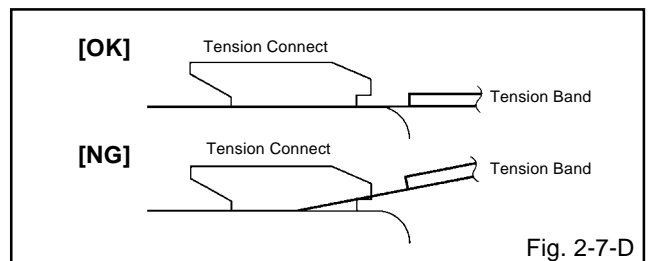
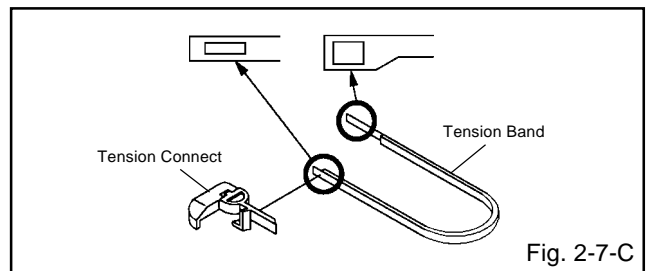

DISASSEMBLY INSTRUCTIONS

2-8: T BRAKE ARM/T BRAKE BAND (Refer to Fig. 2-8-A)

1. Remove the T Brake Spring.
2. Turn the T Brake Arm clockwise and bend the hook section to remove it.
3. Unlock the 2 supports ① and remove the T Brake Band.

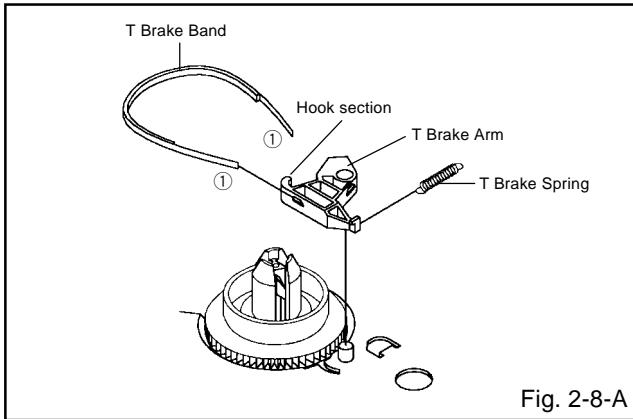

Fig. 2-8-A

NOTE

1. In case of the T Brake Band installation, install correctly as Fig. 2-8-B.

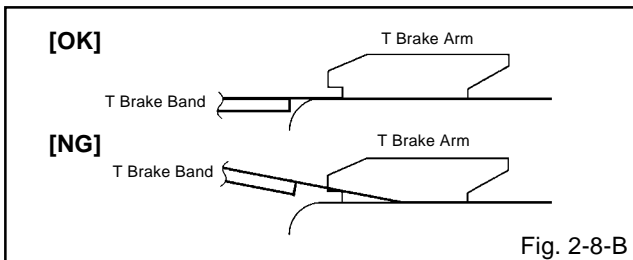

Fig. 2-8-B

2-9: S REEL/T REEL/IDLER ARM ASS'Y/IDLER GEAR (Refer to Fig. 2-9-A)

1. Remove the S Reel and T Reel.
2. Remove the 2 Polyslider Washers ①.
3. Remove the Idler Arm Ass'y and Idler Gear.

NOTE

1. Take care not to damage the gears of the S Reel and T Reel.
2. The Polyslider Washer may be remained on the back of the reel.
3. Take care not to damage the shaft.
4. Do not touch the section "A" of S Reel and T Reel. (Use gloves.) (Refer to Fig. 2-9-A) Do not adhere the stains on it.
5. When you install the reel, clean the shaft and grease it. (If you do not grease, noise may be heard in FF/REW mode.)
6. After installing the reel, adjust the height of the reel. (Refer to MECHANICAL ADJUSTMENT)

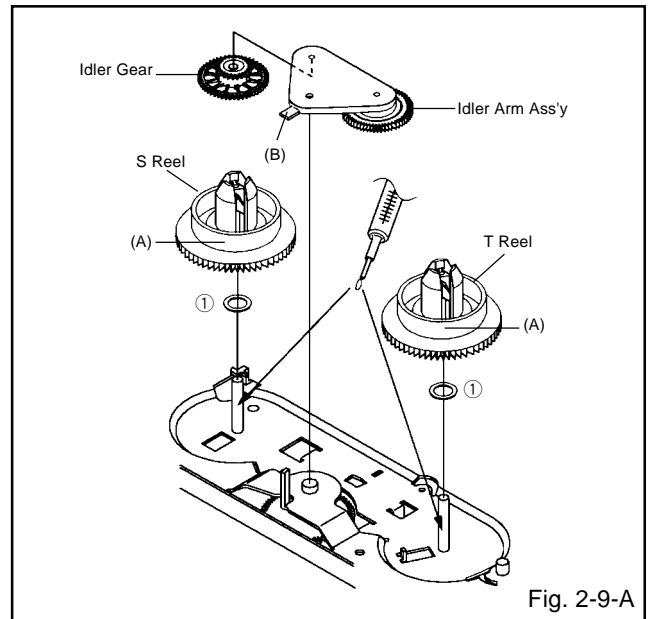

Fig. 2-9-A

NOTE

1. In case of the S Reel and T Reel installation, check if the correct parts are installed. (Refer to Fig. 2-9-B)
2. In case of the Idler Arm Ass'y installation, install correctly as Fig. 2-9-C. And also set it so that the section "B" of Fig. 2-9-A is placed under the Main Chassis tab.

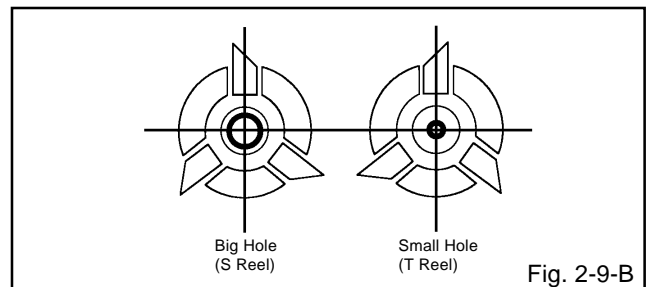

Fig. 2-9-B

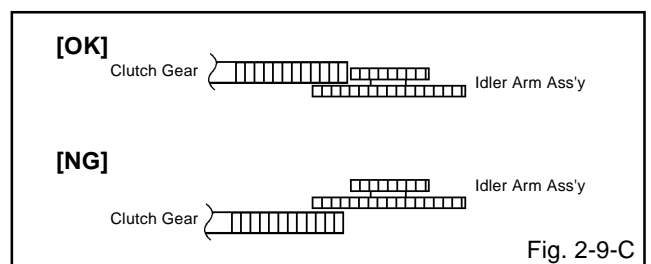
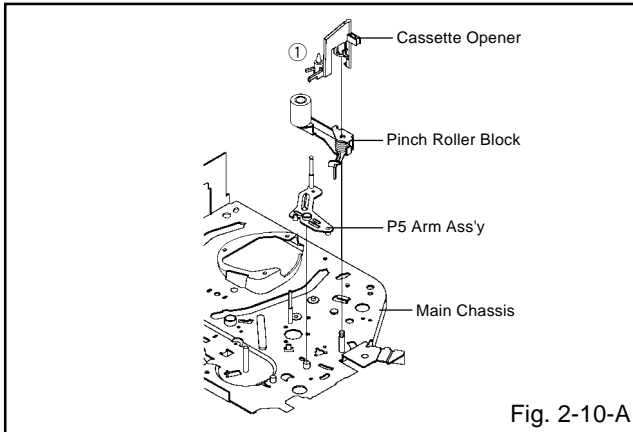

Fig. 2-9-C

DISASSEMBLY INSTRUCTIONS

2-10: CASSETTE OPENER/PINCH ROLLER BLOCK/ P5 ARM ASS'Y (Refer to Fig. 2-10-A)

1. Unlock the support ① and remove the Cassette Opener.
2. Remove the Pinch Roller Block and P5 Arm Ass'y.



NOTE

1. Do not touch the Pinch Roller. (Use gloves.)
2. In case of the Pinch Roller Block and the Pinch Roller Cam installation, install correctly as Fig. 2-10-B.

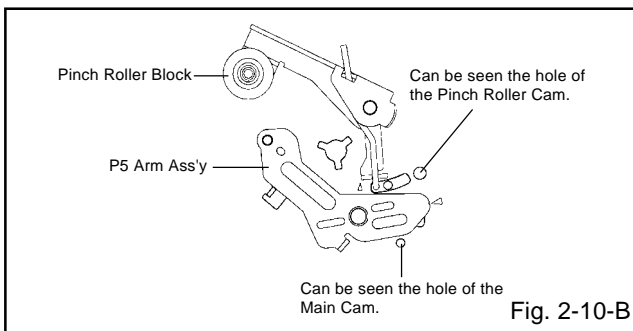

2-11: A/C HEAD (Refer to Fig. 2-11-A)

1. Remove the screw ①.
2. Remove the A/C Head Base.
3. Remove the 3 screws ②.
4. Remove the A/C Head and A/C Head Spring.

NOTE

1. Do not touch the A/C Head. (Use gloves.)
2. When you install the A/C Head Spring, install as shown in Fig. 2-11-B.
3. When you install the A/C Head, tighten the screw (1) first, then tighten the screw (2), finally tighten the screw (3).

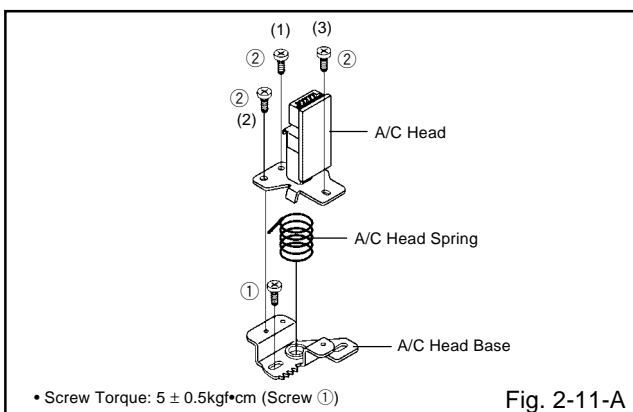

• Screw Torque: $5 \pm 0.5\text{kgf}\cdot\text{cm}$ (Screw ①)

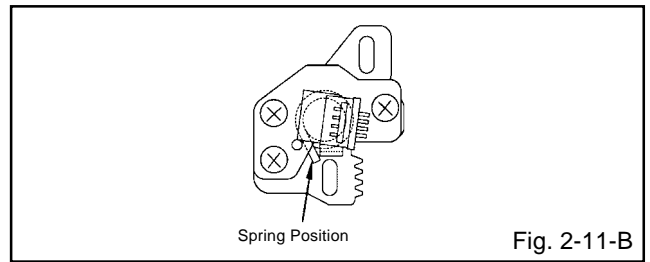

2-12: FE HEAD (RECORDER ONLY) (Refer to Fig. 2-12)

1. Remove the screw ①.
2. Remove the FE Head.

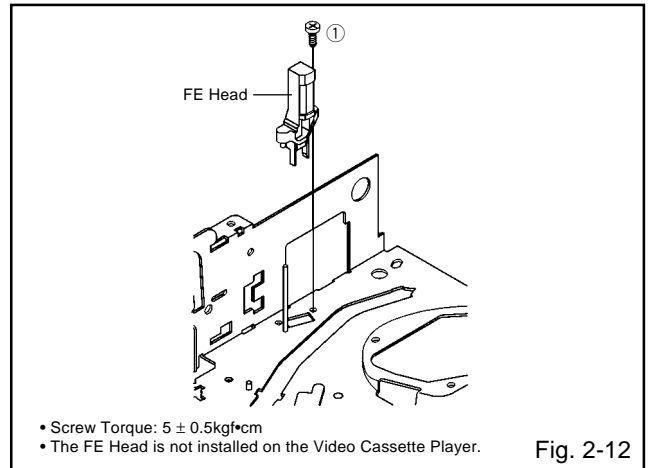

- Screw Torque: $5 \pm 0.5\text{kgf}\cdot\text{cm}$
- The FE Head is not installed on the Video Cassette Player.

2-13: AHC ASS'Y/CYLINDER UNIT ASS'Y (Refer to Fig. 2-13)

1. Disconnect the following connector: (CD2001)
2. Remove the 3 screws ①.
3. Remove the Cylinder Unit Ass'y.

NOTE

1. When you install the Cylinder Unit Ass'y, tighten the screws from (1) to (3) in order while pulling the Ass'y toward the left front direction.

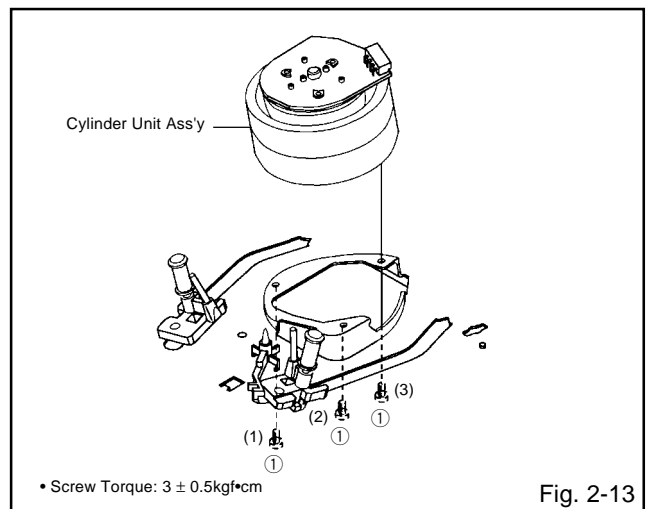

• Screw Torque: $3 \pm 0.5\text{kgf}\cdot\text{cm}$

DISASSEMBLY INSTRUCTIONS

2-14: CAPSTAN DD UNIT (Refer to Fig. 2-14-A)

1. Remove the Capstan Belt.
2. Remove the 3 screws ①.
3. Remove the Capstan DD Unit.

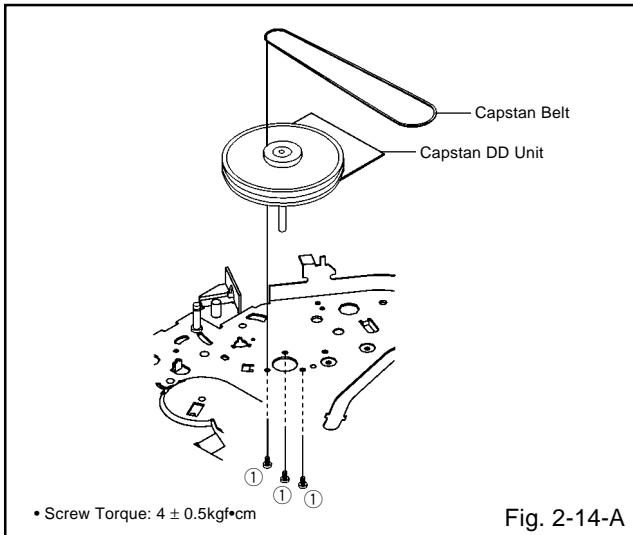

NOTE

1. In case of the Capstan DD Unit installation, apply the silicon bond (TSE3843-W) on the position Fig. 2-14-B correctly. (If no silicon bond applied, abnormal noise will be heard on the deck operation.)
(Refer to Fig. 2-14-B, C)

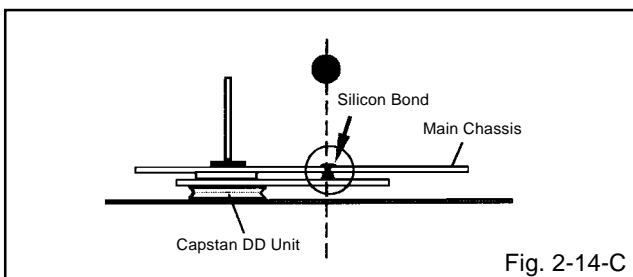
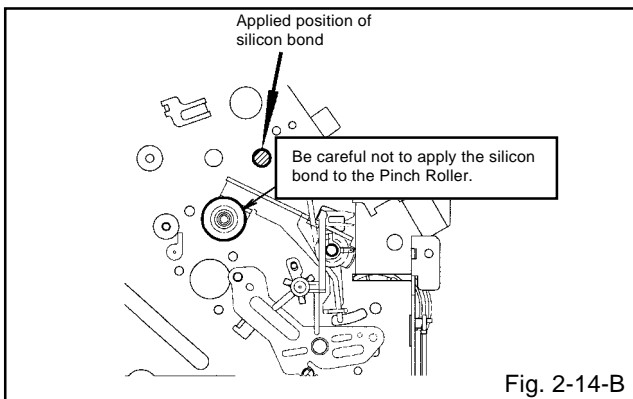

2-15: MAIN CAM/PINCH ROLLER CAM/JOINT GEAR (Refer to Fig. 2-15-A)

1. Remove the E-Ring ①, then remove the Main Cam.
2. Remove the E-Ring ②, then remove the Pinch Roller Cam and Joint Gear.

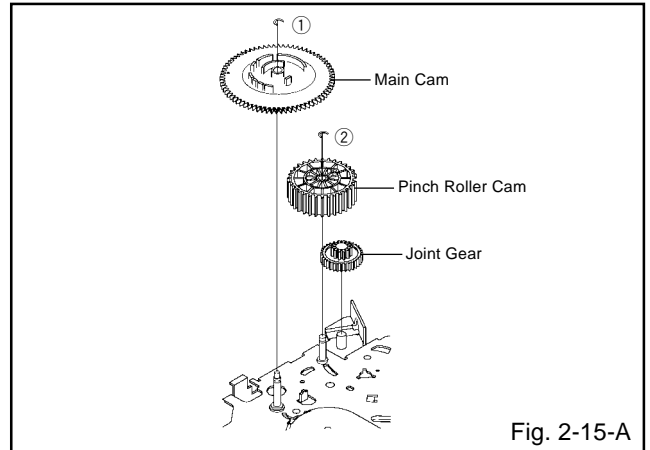

NOTE

1. In case of the Pinch Roller Cam and Main Cam installation, install them as the circled section of Fig. 2-15-B so that the each markers are met. (Refer to Fig. 2-15-B)

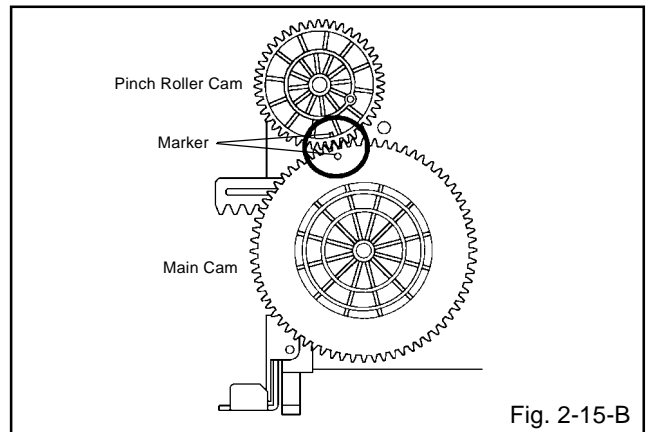

2-16: LOADING GEAR S/T UNIT (Refer to Fig. 2-16-A)

1. Remove the E-Ring ① and remove the Main Loading Gear.
2. Remove the Main Rod, Tension Lever, Loading Arm S Unit and Loading Arm T Unit.

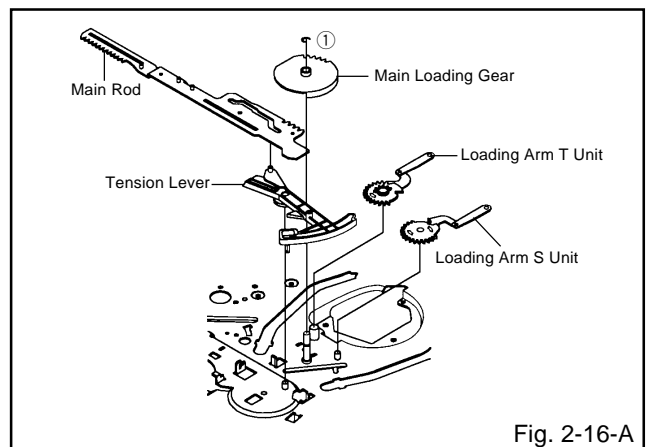

DISASSEMBLY INSTRUCTIONS

NOTE

1. When you install the Loading Arm S Unit, Loading Arm T Unit and Main Loading Gear, align each marker. (Refer to Fig. 2-16-B)

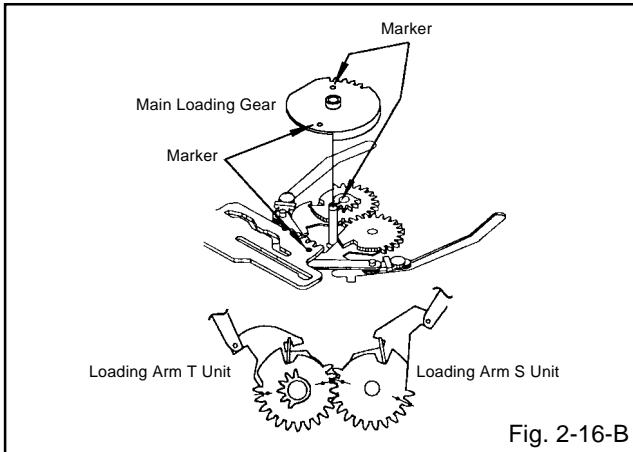

2-17: CLUTCH ASS'Y/RING SPRING/CLUTCH LEVER/CLUTCH GEAR (Refer to Fig. 2-17-A)

1. Remove the Polyslider Washer ①.
2. Remove the Clutch Ass'y and Ring Spring.
3. Remove the Clutch Lever.
4. Remove the Coupling Gear, Coupling Spring and Clutch Gear.

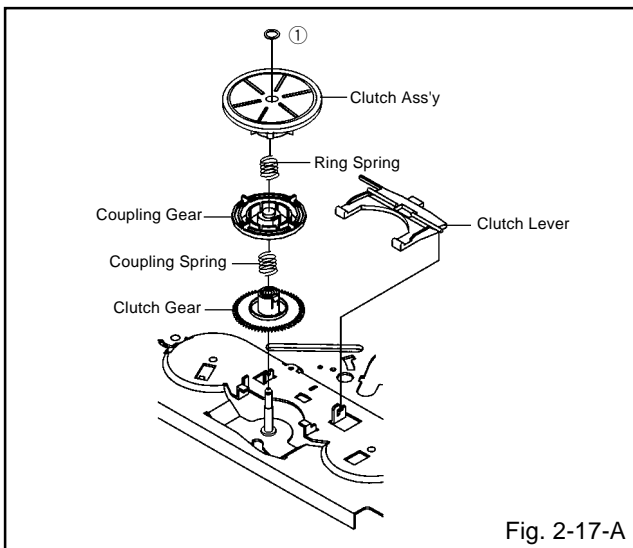

NOTE

1. In case of the Clutch Ass'y installation, install it with inserting the spring of the Clutch Ass'y into the dent of the Coupling Gear. (Refer to Fig. 2-17-B)

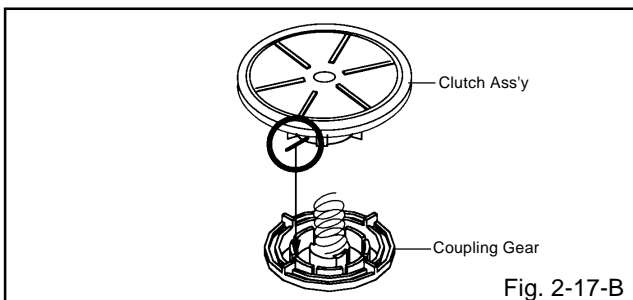

2-18: CASSETTE GUIDE POST/INCLINED BASE S/T UNIT/P4 CAP (Refer to Fig. 2-18-A)

1. Remove the P4 Cap.
2. Unlock the support ① and remove the Cassette Guide Post.
3. Remove the Inclined Base S Unit and Inclined Base T Unit.

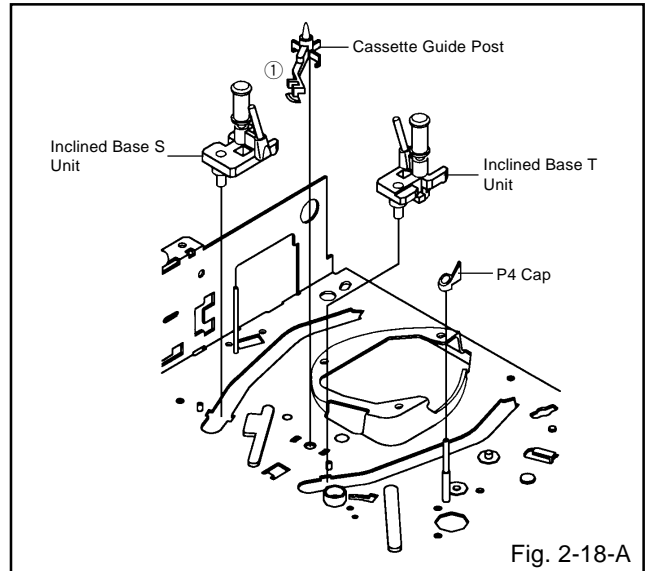

NOTE

1. Do not touch the roller of Guide Roller.
2. In case of the P4 Cap installation, install it with parallel for "A" and "B" of Fig. 2-18-B.
3. In case of the Cassette Guide Post installation, install correctly as the circled section of Fig. 2-18-C.

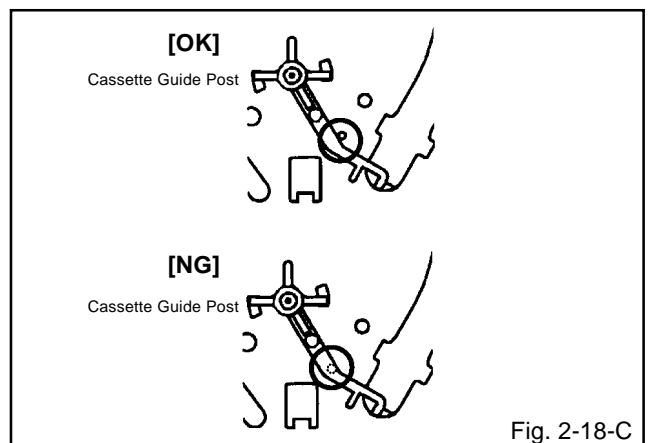
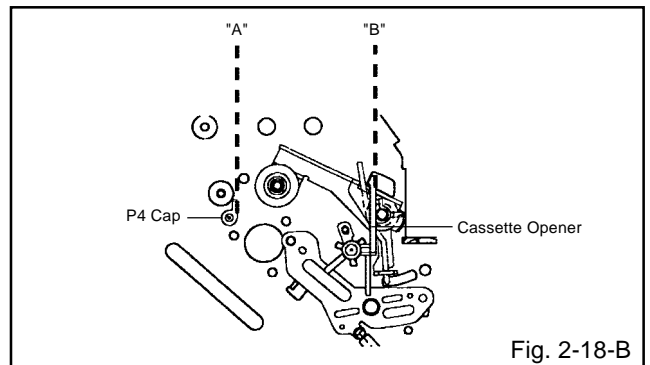

DISASSEMBLY INSTRUCTIONS

3. REMOVAL AND INSTALLATION OF FLAT PACKAGE IC

REMOVAL

1. Put the Masking Tape (cotton tape) around the Flat Package IC to protect other parts from any damage. (Refer to Fig. 3-1.)

NOTE

Masking is carried out on all the parts located within 10 mm distance from IC leads.

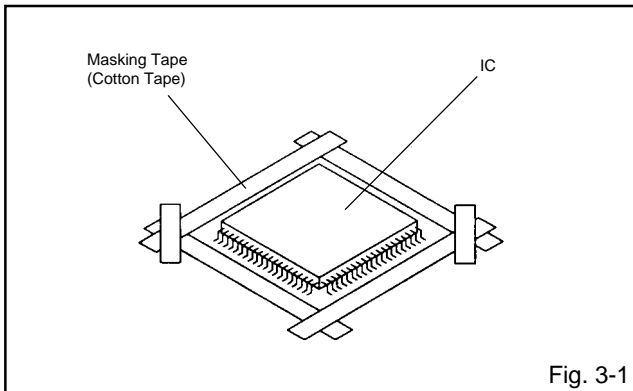

2. Heat the IC leads using a blower type IC desoldering machine. (Refer to Fig. 3-2.)

NOTE

Do not add the rotating and the back and forth directions force on the IC, until IC can move back and forth easily after desoldering the IC leads completely.

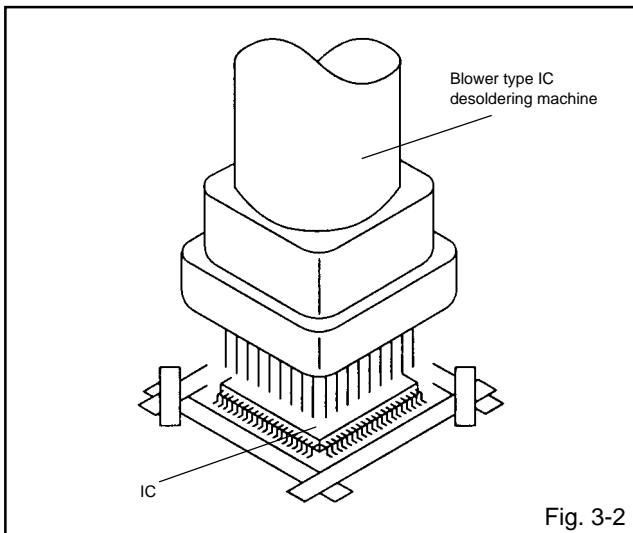

3. When IC starts moving back and forth easily after desoldering completely, pickup the corner of the IC using a tweezers and remove the IC by moving with the IC desoldering machine. (Refer to Fig. 3-3.)

NOTE

Some ICs on the PCB are affixed with glue, so be careful not to break or damage the foil of each IC leads or solder lands under the IC when removing it.

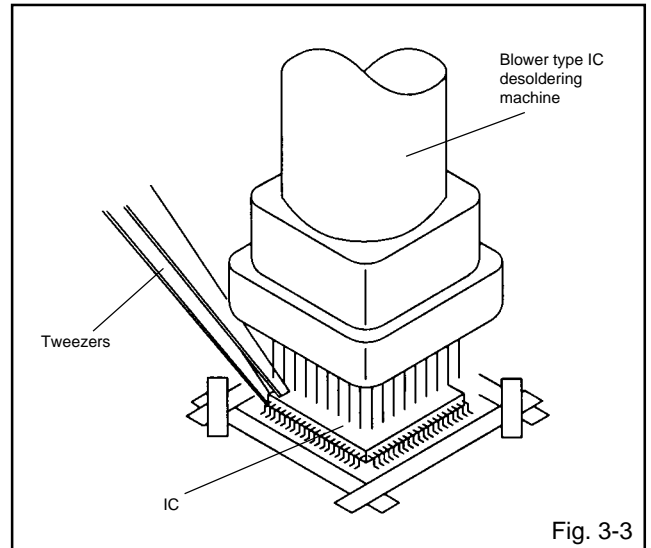

4. Peel off the Masking Tape.
5. Absorb the solder left on the pattern using the Braided Shield Wire. (Refer to Fig. 3-4.)

NOTE

Do not move the Braided Shield Wire in the vertical direction towards the IC pattern.

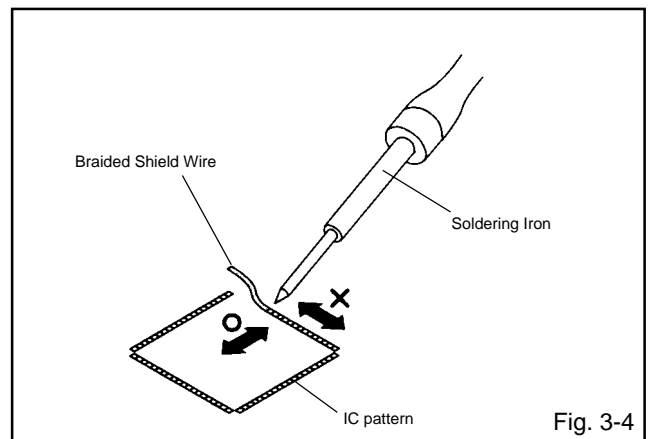

DISASSEMBLY INSTRUCTIONS

INSTALLATION

1. Take care of the polarity of new IC and then install the new IC fitting on the printed circuit pattern. Then solder each lead on the diagonal positions of IC temporarily. (Refer to Fig. 3-5.)

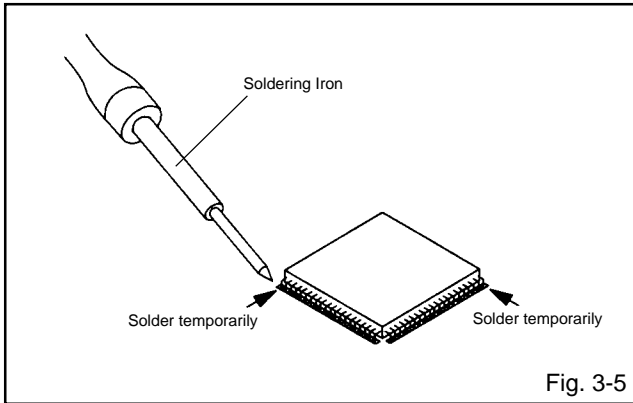

2. Supply the solder from the upper position of IC leads sliding to the lower position of the IC leads. (Refer to Fig. 3-6.)

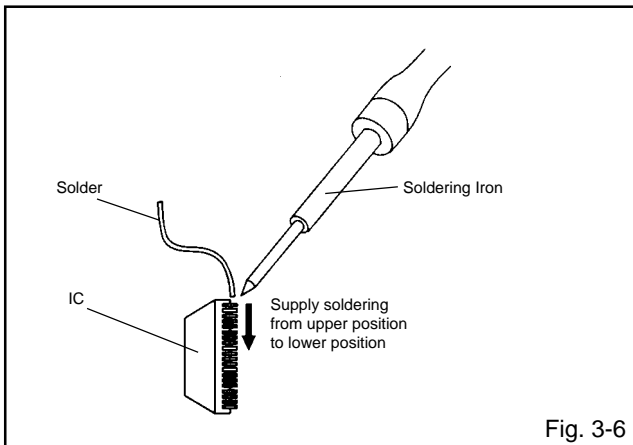

3. Absorb the solder left on the lead using the Braided Shield Wire. (Refer to Fig. 3-7.)

NOTE

Do not absorb the solder to excess.

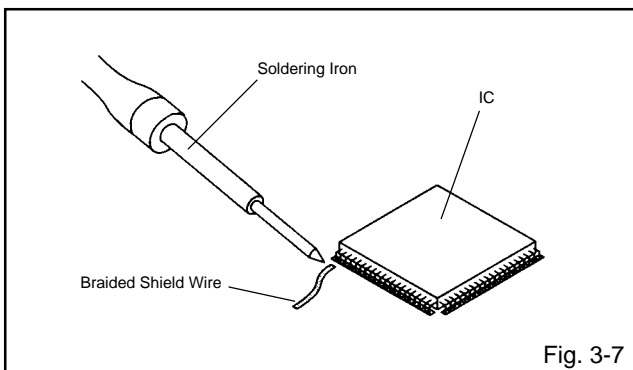

4. When bridge-soldering between terminals and/or the soldering amount are not enough, resolder using a Thin-tip Soldering Iron. (Refer to Fig. 3-8.)

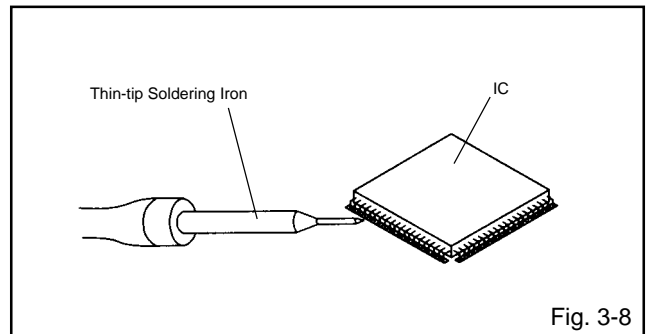

5. Finally, confirm the soldering status on four sides of the IC using a magnifying glass. Confirm that no abnormality is found on the soldering position and installation position of the parts around the IC. If some abnormality is found, correct by resoldering.

NOTE

When the IC leads are bent during soldering and/or repairing, do not repair the bending of leads. If the bending of leads are repaired, the pattern may be damaged. So, be always sure to replace the IC in this case.

KEY TO ABBREVIATIONS

A	A/C	: Audio/Control	H.SW	: Head Switch	
	ACC	: Automatic Color Control	Hz	: Hertz	
	AE	: Audio Erase	I	IC	: Integrated Circuit
	AFC	: Automatic Frequency Control		IF	: Intermediate Frequency
	AFT	: Automatic Fine Tuning		IND	: Indicator
	AFT DET	: Automatic Fine Tuning Detect		INV	: Inverter
	AGC	: Automatic Gain Control	K	KIL	: Killer
	AMP	: Amplifier	L	L	: Left
	ANT	: Antenna		LED	: Light Emitting Diode
	A.PB	: Audio Playback		LIMIT AMP	: Limiter Amplifier
	APC	: Automatic Phase Control		LM, LDM	: Loading Motor
	ASS'Y	: Assembly		LP	: Long Play
	AT	: All Time		L.P.F	: Low Pass Filter
	AUTO	: Automatic		LUMI.	: Luminance
	A/V	: Audio/Video	M	M	: Motor
B	BGP	: Burst Gate Pulse		MAX	: Maximum
	BOT	: Beginning of Tape		MINI	: Minimum
	BPF	: Bandpass Filter		MIX	: Mixer, mixing
	BRAKE SOL	: Brake Solenoid		MM	: Monostable Multivibrator
	BUFF	: Buffer		MOD	: Modulator, Modulation
	B/W	: Black and White		MPX	: Multiplexer, Multiplex
C	C	: Capacitance, Collector		MS SW	: Mecha State Switch
	CASE	: Cassette	N	NC	: Non Connection
	CAP	: Capstan		NR	: Noise Reduction
	CARR	: Carrier	O	OSC	: Oscillator
	CH	: Channel		OPE	: Operation
	CLK	: Clock	P	PB	: Playback
	CLOCK (SY-SE)	: Clock (Syscon to Servo)		PB CTL	: Playback Control
	COMB	: Combination, Comb Filter		PB-C	: Playback-Chrominance
	CONV	: Converter		PB-Y	: Playback-Luminance
	CPM	: Capstan Motor		PCB	: Printed Circuit Board
	CTL	: Control		P. CON	: Power Control
	CYL	: Cylinder		PD	: Phase Detector
	CYL-M	: Cylinder-Motor		PG	: Pulse Generator
	CYL SENS	: Cylinder-Sensor		P-P	: Peak-to Peak
D	DATA (SY-CE)	: Data (Syscon to Servo)	R	R	: Right
	dB	: Decibel		REC	: Recording
	DC	: Direct Current		REC-C	: Recording-Chrominance
	DD Unit	: Direct Drive Motor Unit		REC-Y	: Recording-Luminance
	DEMODO	: Demodulator		REEL BRK	: Reel Brake
	DET	: Detector		REEL S	: Reel Sensor
	DEV	: Deviation		REF	: Reference
E	E	: Emitter		REG	: Regulated, Regulator
	EF	: Emitter Follower		REW	: Rewind
	EMPH	: Emphasis		REV, RVS	: Reverse
	ENC	: Encoder		RF	: Radio Frequency
	ENV	: Envelope		RMC	: Remote Control
	EOT	: End of Tape		RY	: Relay
	EQ	: Equalizer	S	S. CLK	: Serial Clock
	EXT	: External		S. COM	: Sensor Common
F	F	: Fuse		S. DATA	: Serial Data
	FBC	: Feed Back Clamp		SEG	: Segment
	FE	: Full Erase		SEL	: Select, Selector
	FF	: Fast Forward, Flip-flop		SENS	: Sensor
	FG	: Frequency Generator		SER	: Search Mode
	FL SW	: Front Loading Switch		SI	: Serial Input
	FM	: Frequency Modulation		SIF	: Sound Intermediate Frequency
	FSC	: Frequency Sub Carrier		SO	: Serial Output
	FWD	: Forward		SOL	: Solenoid
G	GEN	: Generator		SP	: Standard Play
	GND	: Ground		STB	: Serial Strobe
H	H.P.F	: High Pass Filter		SW	: Switch

KEY TO ABBREVIATIONS

S	SYNC	:	Synchronization
	SYNC SEP	:	Sync Separator, Separation
T	TR	:	Transistor
	TRAC	:	Tracking
	TRICK PB	:	Trick Playback
	TP	:	Test Point
U	UNREG	:	Unregulated
V	V	:	Volt
	VCO	:	Voltage Controlled Oscillator
	VIF	:	Video Intermediate Frequency
	VP	:	Vertical Pulse, Voltage Display
	V.PB	:	Video Playback
	VR	:	Variable Resistor
	V.REC	:	Video Recording
	VSF	:	Visual Search Fast Forward
	VSR	:	Visual Search Rewind
	VSS	:	Voltage Super Source
	V-SYNC	:	Vertical-Synchronization
	VT	:	Voltage Tuning
X	X'TAL	:	Crystal
Y	Y/C	:	Luminance/Chrominance

SERVICE MODE LIST

This unit provided with the following SERVICE MODES so you can repair, examine and adjust easily.

Method	Operations
Press the ATR button on the remote control for more than 2 seconds during PLAY.	Adjusting of the Tracking to the center position. Refer to the "MECHANICAL ADJUSTMENT" (GUIDE ROLLER) and "ELECTRICAL ADJUSTMENT" (PG SHIFTER).
Make the short circuit between the test point of SERVICE and the GND.	The BOT, EOT, and the Reel Sensor do not work and the deck can be operated without a cassette tape. Refer to the "PREPARATION FOR SERVICING"

PREVENTIVE CHECKS AND SERVICE INTERVALS

The following standard table depends on environmental conditions and usage.
 Parts replacing time does not mean the life span for individual parts.
 Also, long term storage or misuse may cause transformation and aging of rubber parts.
 The following list means standard hours, so the checking hours depends on the conditions.

Time Parts Name	500 hours	1,000 hours	1,500 hours	2,000 hours	2,500 hours	Notes
Audio Control Head	■	■	■	●	●	Clean those parts in contact with the tape.
Full Erase Head (Recorder only)	■	■	■	●	●	
Capstan Belt		●	●	●	●	Clean the rubber, and parts which the rubber touches.
Pinch Roller	■	●	●	●	●	
Capstan DD Unit		●	●	●	●	
Loading Motor					●	
Tension Band		●	●	●	●	
T Brake Band		●	●	●	●	
Clutch Ass'y		●	●	●	●	
Idler Arm Ass'y		●	●	●	●	
Capstan Shaft	■	■	■	■	■	
Tape Running Guide Post	■	■	■	■	■	Replace when rolling becomes abnormal.
Cylinder Unit	■	●	●	●	●	Clean the Head

■ : Clean
 ● : Check it and if necessary, replace it.

CLEANING

NOTE

After cleaning the heads with isopropyl alcohol, do not run a tape until the heads dry completely. If the heads are not completely dry and alcohol gets on the tape, damage may occur.

1. AUDIO CONTROL HEAD

Clean the Audio Control Head with the cotton stick soaked by alcohol. Clean the full erase head in the same manner. (Refer to the figure below.)

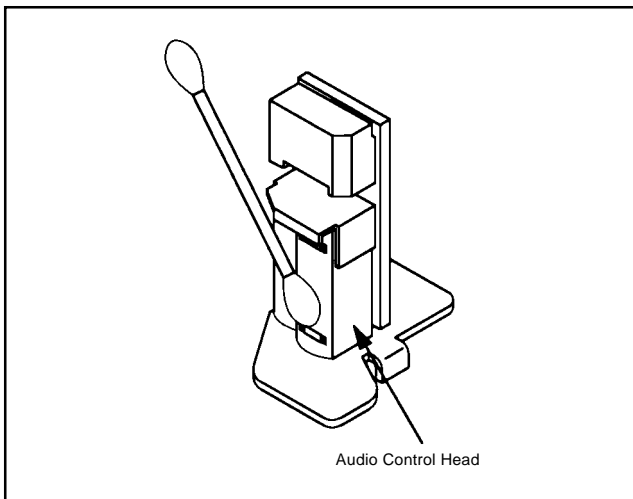

2. TAPE RUNNING SYSTEM

When cleaning the tape transport system, use the gauze moistened with isopropyl alcohol.

3. CYLINDER



Wrap a piece of chamois around your finger. Dip it in isopropyl alcohol. Hold it to the cylinder head softly. Turn the cylinder head counterclockwise to clean it (in the direction of the arrow). (Refer to the figure below.)

NOTE

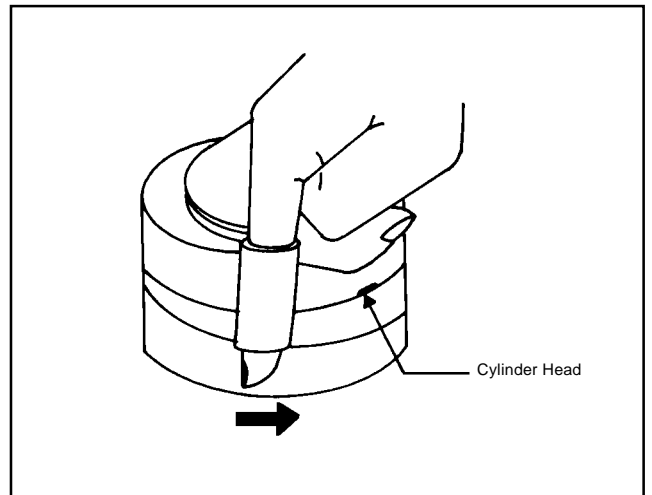
Do not exert force against the cylinder head. Do not move the chamois upward or downward on the head. Use the chamois one by one.

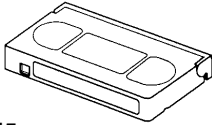
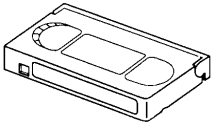
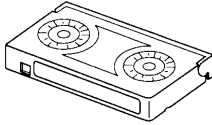
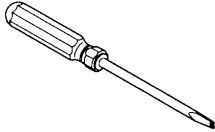
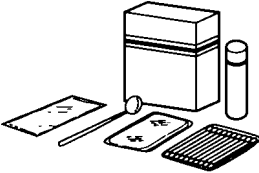

SERVICING FIXTURES AND TOOLS

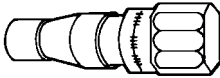
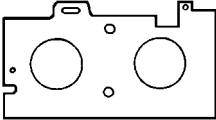
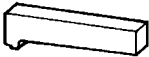
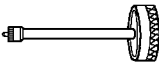
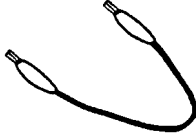
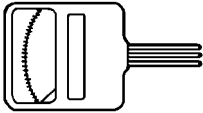
<p>Alignment Tape</p>  <p>ST-N5 ST-NF</p>	<p>Back tension cassette gauge</p>  <p>70909103</p>	<p>Torque cassette gauge (KT-300NR)</p>  <p>70909199</p>	<p>Taper nut driver</p>  <p>70909228</p>
<p>VTR cleaning kit</p> 	<p>VTR lubrication kit</p> 	<p>Grease</p> 	<p>JG002B Adapter JG002E Dial Torque Gauge (10~90gf•cm) JG002F (60~600gf•cm)</p> 
<p>JG022 Master Plane</p> 	<p>JG024A Reel Disk Height Adjustment Jig</p> 	<p>JG153 X Value Adjustment Screwdriver</p> 	<p>JG154 Cable</p> 
<p>Tentelometer</p> 			

Ref. No.	Part No.	Parts Name	Remarks
JG002B	APJG002B00	Adapter	VSR Torque, Brake Torque (S Reel/T Reel Ass'y)
JG002E	APJG002E00	Dial Torque Gauge (10~90gf•cm)	Brake Torque (T Reel Ass'y)
JG002F	APJG002F00	Dial Torque Gauge (60~600gf•cm)	VSR Torque, Brake Torque (S Reel)
JG022	APJG022000	Master Plane	Reel Disk Height Adjustment
JG024A	APJG024A00	Reel Disk Height Adjustment Jig	Reel Disk Height Adjustment
JG153	APJG153000	X Value Adjustment Screwdriver	X Value Adjustment
JG154	APJG154000	Cable	Used to connect the test point of SERVICE and GROUND

PREPARATION FOR SERVICING

How to use the Servicing Fixture

- Short circuit between **TP1001** and **Ground** with the cable JG154.
(The BOT, EOT, and the Reel Sensor do not work and the deck can be operated without a cassette tape.)
- In case of using a cassette tape, press the STOP/EJECT button to insert or eject a cassette tape.
Turn on the power and re-check the cable before checking the trouble points.

MECHANICAL ADJUSTMENTS

1. CONFIRMATION AND ADJUSTMENT

Read the following NOTES before starting work.

- Place an object which weighs between 450g~500g on the Cassette Tape to keep it steady when you want to make the tape run without the Cassette Holder. (Do not place an object which weighs over 500g.)

1-1: CONFIRMATION AND ADJUSTMENT OF REEL DISK HEIGHT

- Turn on the power and set to the STOP mode.
- Set the master plane (**JG022**) and reel disk height adjustment jig (**JG024A**) on the mechanism framework, taking care not to scratch the drum, as shown in **Fig. 1-1-A**.
- While turning the reel and confirm the following points. Check if the surface "A" of reel disk is lower than the surface "B" of reel disk height adjustment jig (**JG024A**) and is higher than the surface "C". If it is not passed, place the height adjustment washers and adjust to 10(+2, -0)mm.
- Adjust the other reel in the same way.

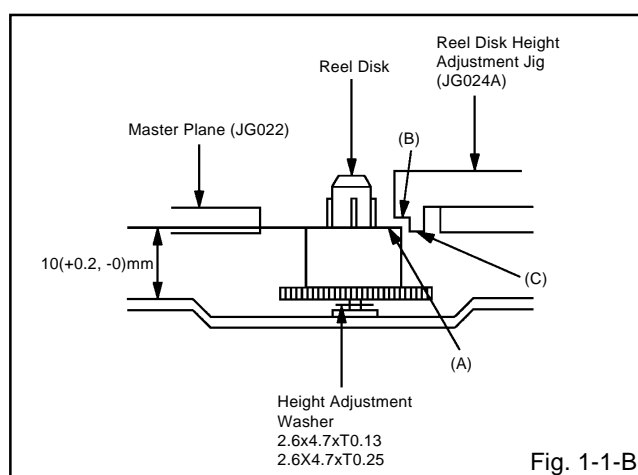
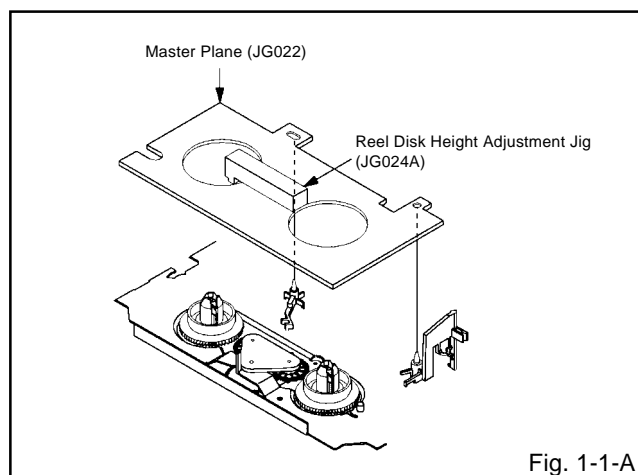

1-2: CONFIRMATION AND ADJUSTMENT OF TENSION POST POSITION

- Set to the PLAY mode.
- Adjust the adjusting section for the Tension Arm position so that the Tension Arm top is within the standard line of Main Chassis.
- While turning the S Reel clockwise, confirm that the edge of the Tension Arm is located in the position described above.

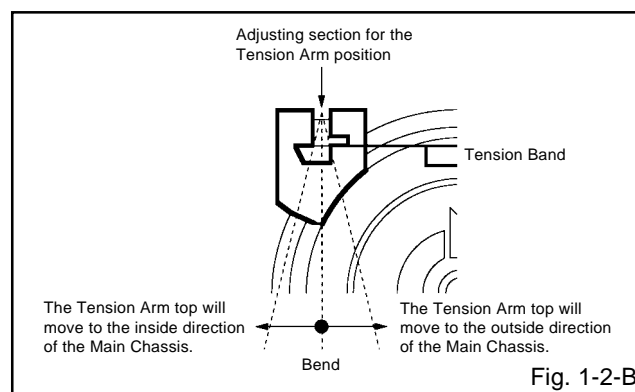
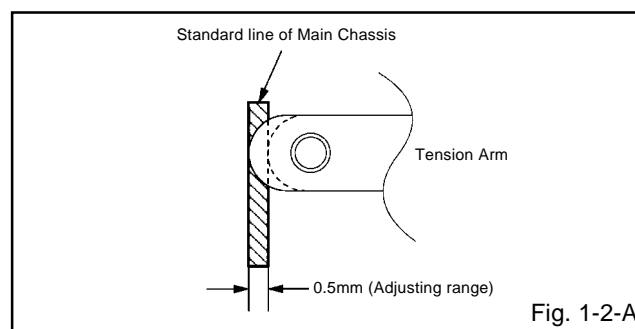

1-3: CONFIRMATION OF PLAYBACK TORQUE AND BACK TENSION TORQUE DURING PLAYBACK

- Load a video tape (T-120) recorded in standard speed mode. Set the unit to the PLAY mode.
- Install the tentelometer as shown in **Fig. 1-3**. Confirm that the meter indicates $20 \pm 2\text{gf}$ in the beginning of playback.

• USING A CASSETTE TYPE TORQUE TAPE (**KT-300NR**)

- After confirmation and adjustment of Tension Post position (**Refer to item 1-2**), load the cassette type torque tape (**KT-300NR**) and set to the PLAY mode.
- Confirm that the right meter of the torque tape indicates 50~90gf•cm during playback in SP mode.
- Confirm that the left meter of the torque tape indicates 25~40gf•cm during playback in SP mode.

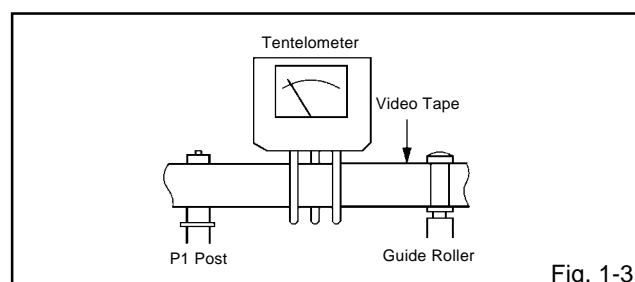

MECHANICAL ADJUSTMENTS

1-4: CONFIRMATION OF VSR TORQUE

1. Install the Torque Gauge (JG002F) and Adapter (JG002B) on the S Reel. Set to the Picture Search (Rewind) mode. (Refer to Fig.1-4-B)
2. Then, confirm that it indicates 120~180gf•cm.

NOTE

Install the Torque Gauge on the reel disk firmly. Press the REW button to turn the reel disk.

1-5: CONFIRMATION OF REEL BRAKE TORQUE

(S Reel Brake) (Refer to Fig. 1-4-B)

1. Once set to the Fast Forward mode then set to the Stop mode. While, unplug the AC cord when the Pinch Roller Block is on the position of Fig. 1-4-A.
2. Move the Idler Ass'y from the S Reel.
3. Install the Torque Gauge (JG002F) and Adapter (JG002B) on the S Reel. Turn the Torque Gauge (JG002F) clockwise.
4. Then, confirm that it indicates 60~100gf•cm.

(T Reel Brake) (Refer to Fig. 1-4-B)

1. Once set to the Fast Forward mode then set to the Stop mode. While, unplug the AC cord when the Pinch Roller Block is on the position of Fig. 1-4-A.
2. Move the Idler Ass'y from the T Reel.
3. Install the Torque Gauge (JG002E) and Adapter (JG002B) on the T reel. Turn the Torque Gauge (JG002E) counterclockwise.
4. Then, confirm that it indicates 30~50gf•cm.

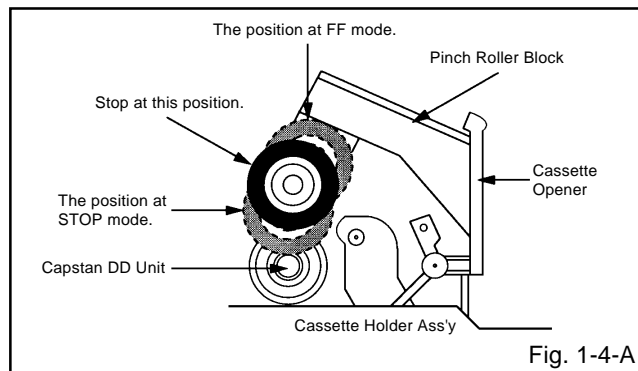

Fig. 1-4-A

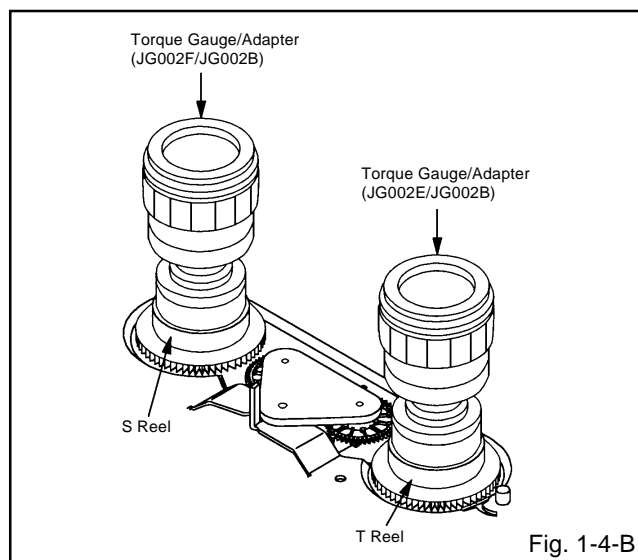

Fig. 1-4-B

NOTE

If the torque is out of the range, replace the following parts.

Check item	Replacement Part
1-4	Idler Ass'y/Clutch Ass'y
1-5	S Reel side: S Reel/Tension Band/Tension Connect/Tension Arm Ass'y T Reel side: T Reel/T Brake Band//T Brake Spring/T Brake Arm

2. CONFIRMATION AND ADJUSTMENT OF TAPE RUNNING MECHANISM

Tape Running Mechanism is adjusted precisely at the factory. Adjustment is not necessary as usual. When you replace the parts of the tape running mechanism because of long term usage or failure, the confirmation and adjustment are necessary.

2-1: GUIDE ROLLER

1. Playback the VHS Alignment Tape.
2. Connect CH-1 of the oscilloscope to TP4001 (Envelope) and CH-2 to TP1002 (SW Pulse).
3. Press and hold the Tracking-Auto button on the remote control more than 2 seconds to set tracking to center.
4. Trigger with SW Pulse and observe the envelope. (Refer to Fig. 2-1-A)
5. When observing the envelope, adjust the Taper Nut Driver slightly until the envelope will be flat. Even if you press the Tracking Button, adjust so that flatness is not moved so much.
6. Adjust so that the A : B ratio is better than 3 : 2 as shown in Fig. 2-1-B, even if you press the Tracking Button to move the envelope (The envelope waveform will begin to decrease when you press the Tracking Button).
7. Adjust the PG shifter during playback. (Refer to the ELECTRICAL ADJUSTMENTS)

NOTE

After adjustment, confirm and adjust A/C head. (Refer to item 2-2)

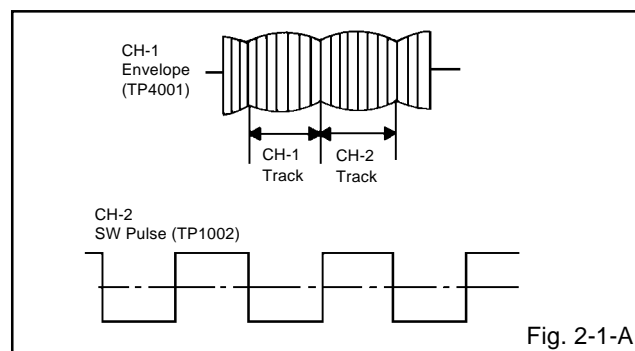

Fig. 2-1-A

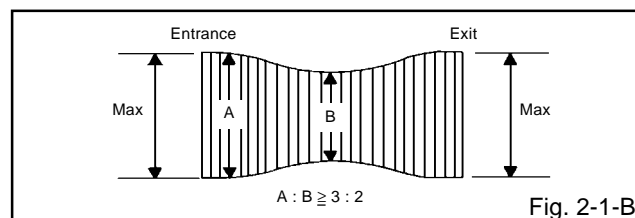

Fig. 2-1-B

MECHANICAL ADJUSTMENTS

2-2: CONFIRMATION AND ADJUSTMENT OF AUDIO/CONTROL HEAD

When the Tape Running Mechanism does not work well, adjust the following items.

1. Playback the VHS Alignment Tape.
2. Confirm that the reflected picture of stamp mark is appeared on the tape prior to P4 Cap as shown in **Fig. 2-2-A**.
 - a) When the reflected picture is distorted, turn the screw ① clockwise until the distortion is disappeared.
 - b) When the reflected picture is not distorted, turn the screw ① counterclockwise until little distortion is appeared, then adjust the a).
3. Turn the screw ② to set the audio level to maximum.
4. Confirm that the bottom of the Audio/Control Head and the bottom of the tape is shown in **Fig. 2-2-C**.
 - c) When the height is not correct, turn the screw ③ to adjust the height. Then, adjust the 1~3 again.

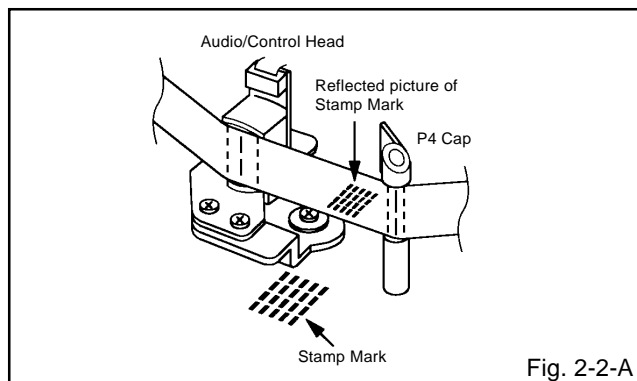

Fig. 2-2-A

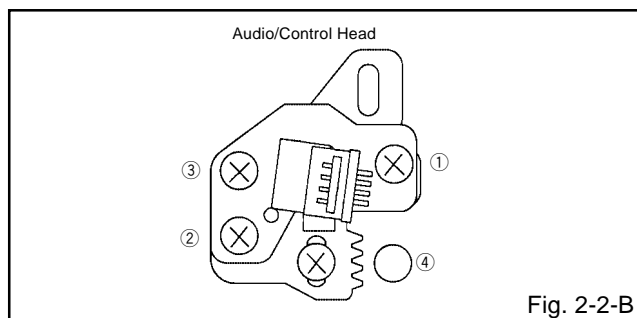

Fig. 2-2-B

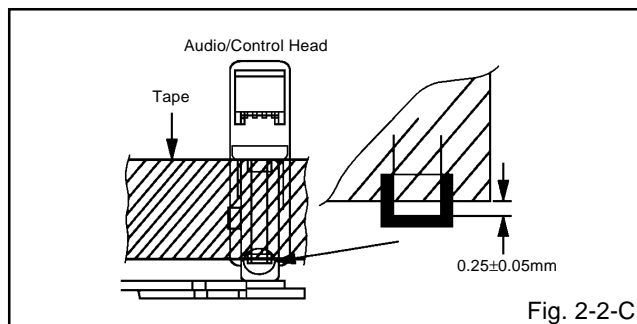

Fig. 2-2-C

2-3: TAPE RUNNING ADJUSTMENT (X VALUE ADJUSTMENT)

1. Confirm and adjust the height of the Reel Disk. **(Refer to item 1-1)**
2. Confirm and adjust the position of the Tension Post. **(Refer to item 1-2)**
3. Adjust the Guide Roller. **(Refer to item 2-1)**
4. Confirm and adjust the Audio/Control Head. **(Refer to item 2-2)**
5. Connect CH-1 of the oscilloscope to **TP1002**, CH-2 to **TP4001** and CH-3 to **HOT side of Audio Out Jack**.
6. Playback the VHS Alignment Tape.
7. Press and hold the Tracking-Auto button on the remote control more than 2 seconds to set tracking to center.
8. Set the X Value adjustment driver (**JG153**) to the ④ of **Fig. 2-2-B**. Adjust X value so that the envelope waveform output becomes maximum. Check if the relation between Audio and Envelope waveform becomes (1) or (2) of **Fig. 2-3**.

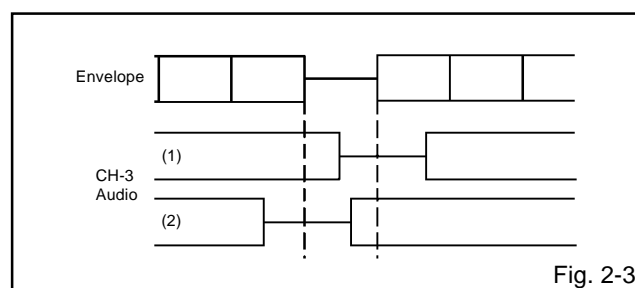
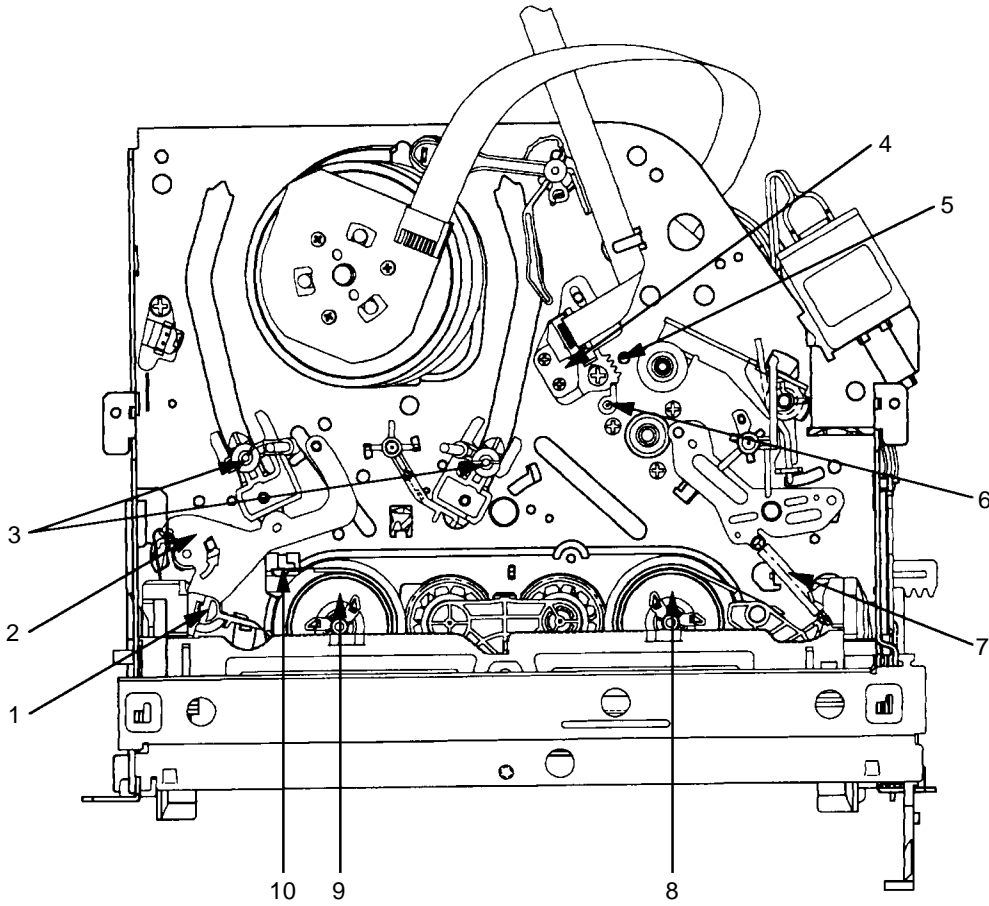

Fig. 2-3

MECHANICAL ADJUSTMENTS

3. MECHANISM ADJUSTMENT PARTS LOCATION GUIDE



- | | |
|-----------------------------------|--|
| 1. Tension Connect | 6. P4 Post |
| 2. Tension Arm | 7. T Brake Spring |
| 3. Guide Roller | 8. T Reel |
| 4. Audio/Control Head | 9. S Reel |
| 5. X value adjustment driver hole | 10. Adjusting section for the Tension Arm position |

ELECTRICAL ADJUSTMENTS

Read and perform this adjustment when repairing the circuits or replacing electrical parts or PCB assemblies.

1. BASIC ADJUSTMENT

CAUTION

When you exchange IC and Transistor for a heat sink, apply the silicon grease on the contact section of the heat sink. Before applying new silicon grease, remove all the old silicon grease. (Old grease may cause damages to the IC and Transistor.)

1-1: PG SHIFTER

CONDITIONS

MODE-PLAYBACK
Input Signal-Alignment Tape

INSTRUCTIONS

1. Connect CH-1 on the oscilloscope to **TP1002** and CH-2 to **TP4201**.
2. Playback the alignment tape.
3. Press and hold the Tracking-Auto button on the remote control more than 2 seconds to set tracking to center.
4. Adjust the **VR1001** until the waveforms of the oscilloscope measures $6.5 \pm 0.5(H)$ at both leading and trailing edges. (Refer to Fig. 1-1-A, B)

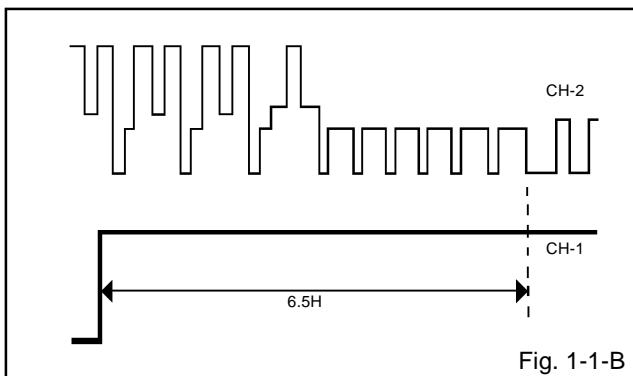
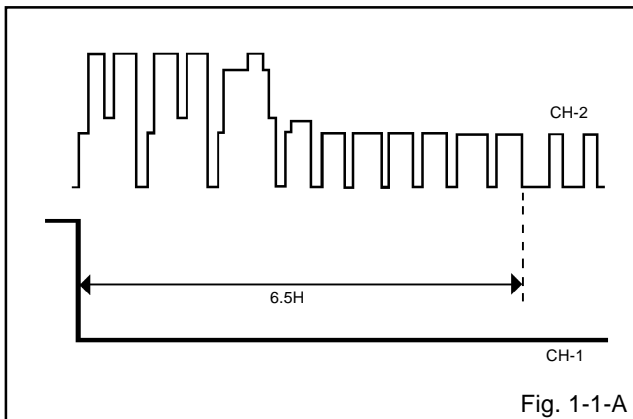

ELECTRICAL ADJUSTMENTS

2. ELECTRICAL ADJUSTMENT PARTS LOCATION GUIDE

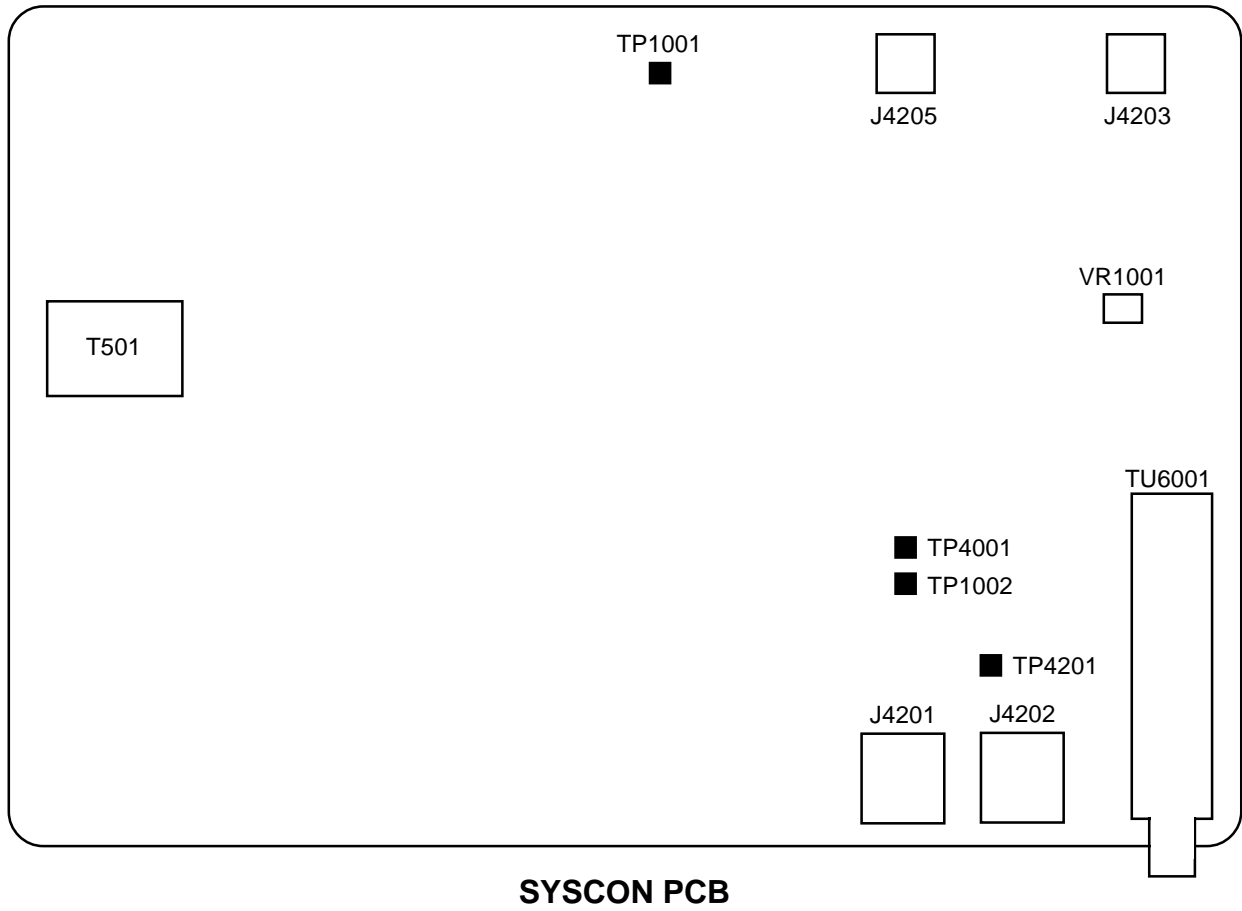

SYSTEM CONTROL/SERVO BLOCK DIAGRAM

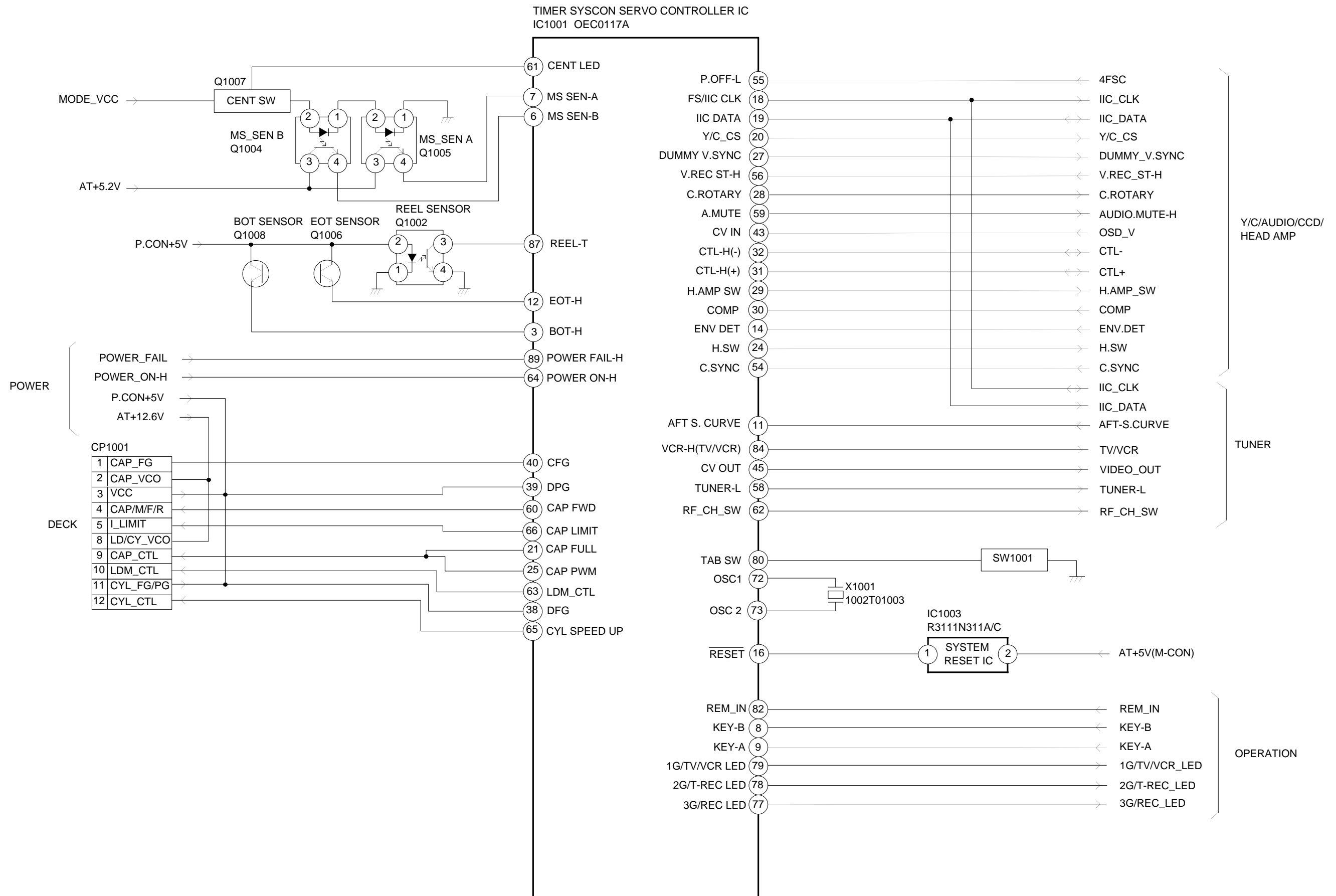

TUNER BLOCK DIAGRAM

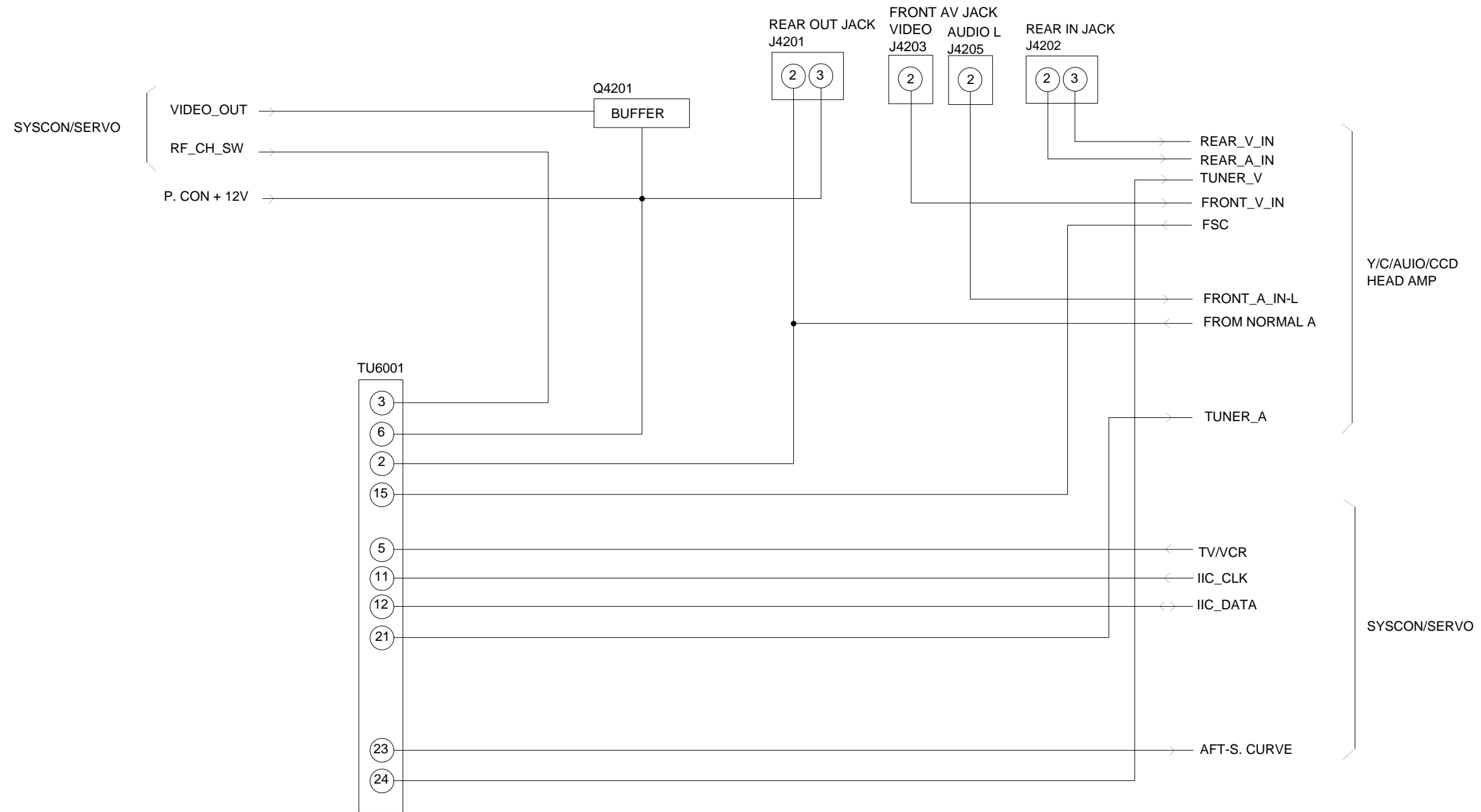

OPERATION BLOCK DIAGRAM

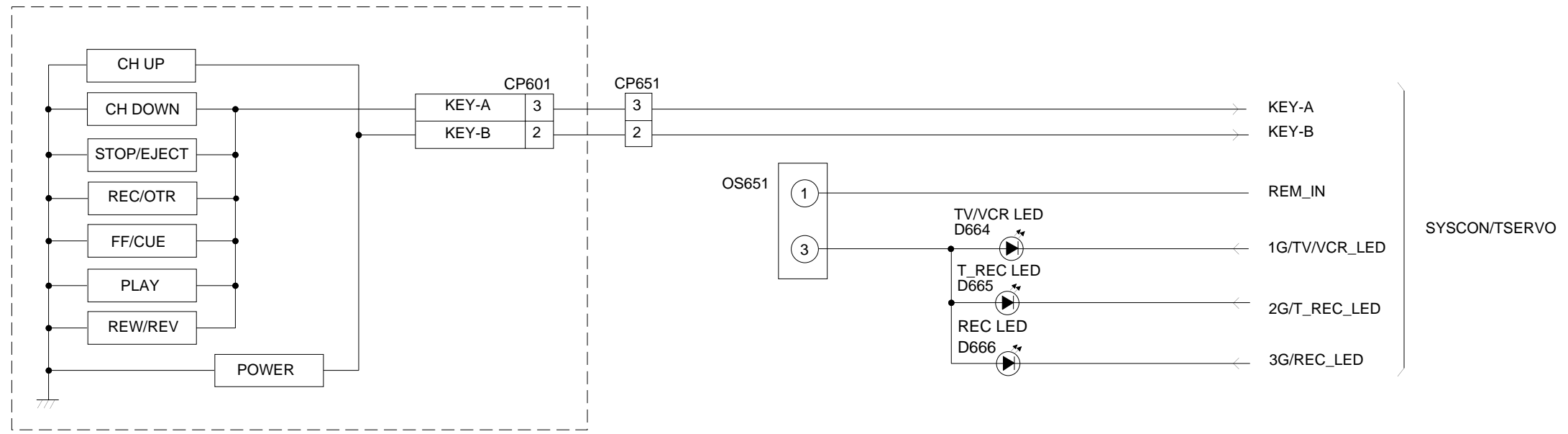

POWER BLOCK DIAGRAM

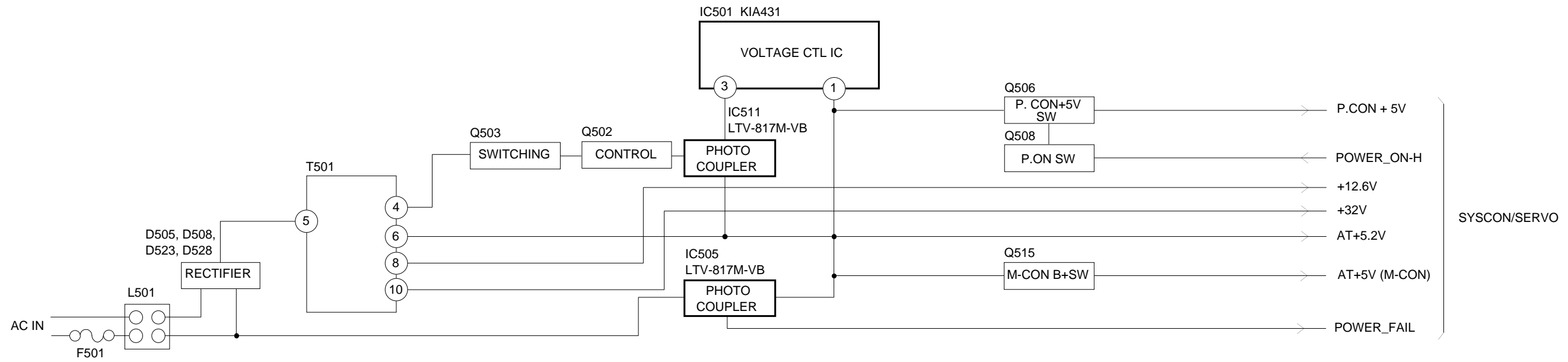

**PRINTED CIRCUIT BOARDS
SYSCON/OPERATION (INSERTED PARTS)
SOLDER SIDE**

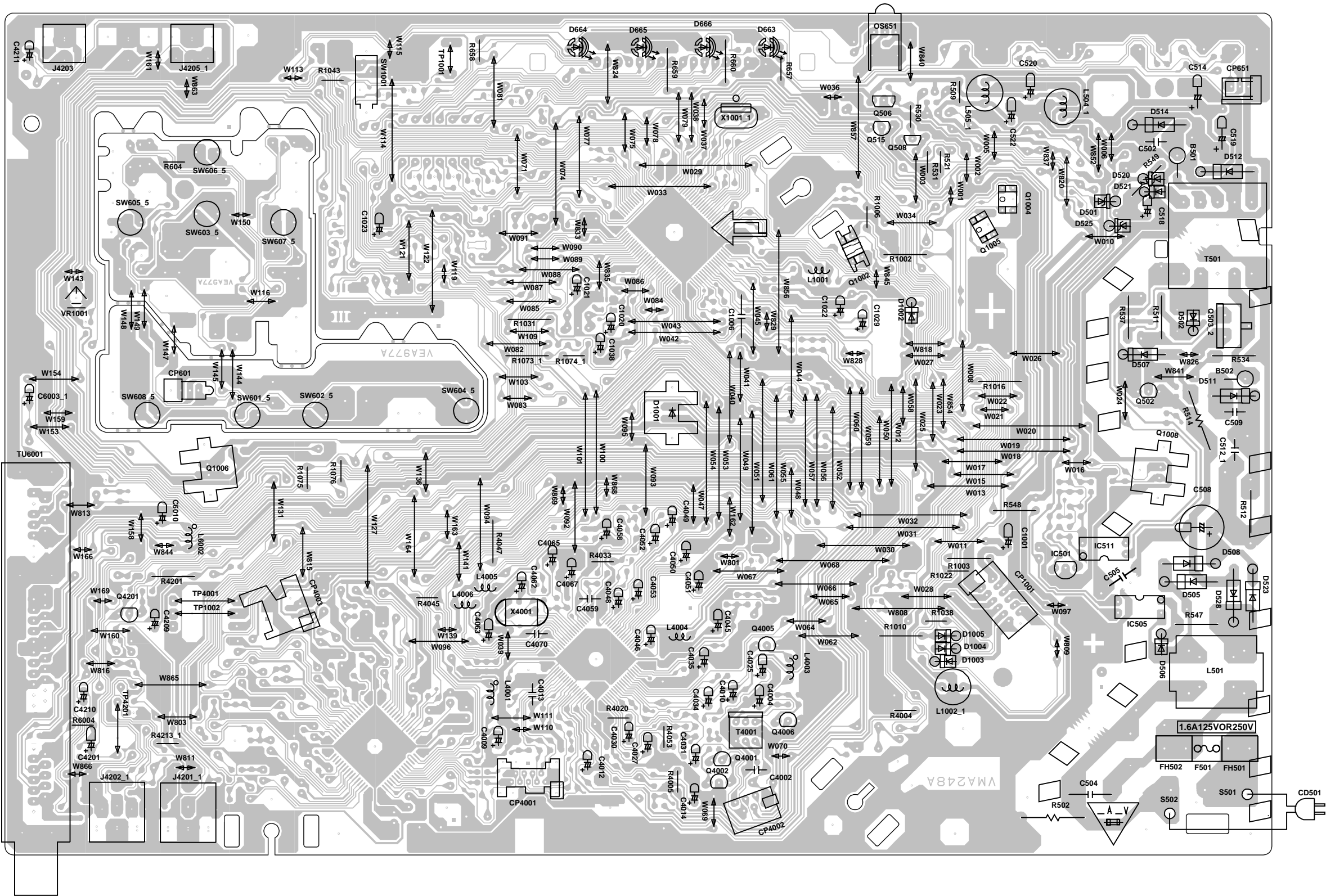

PRINTED CIRCUIT BOARDS
SYSCON/OPERATION (CHIP MOUNTED PARTS)
SOLDER SIDE

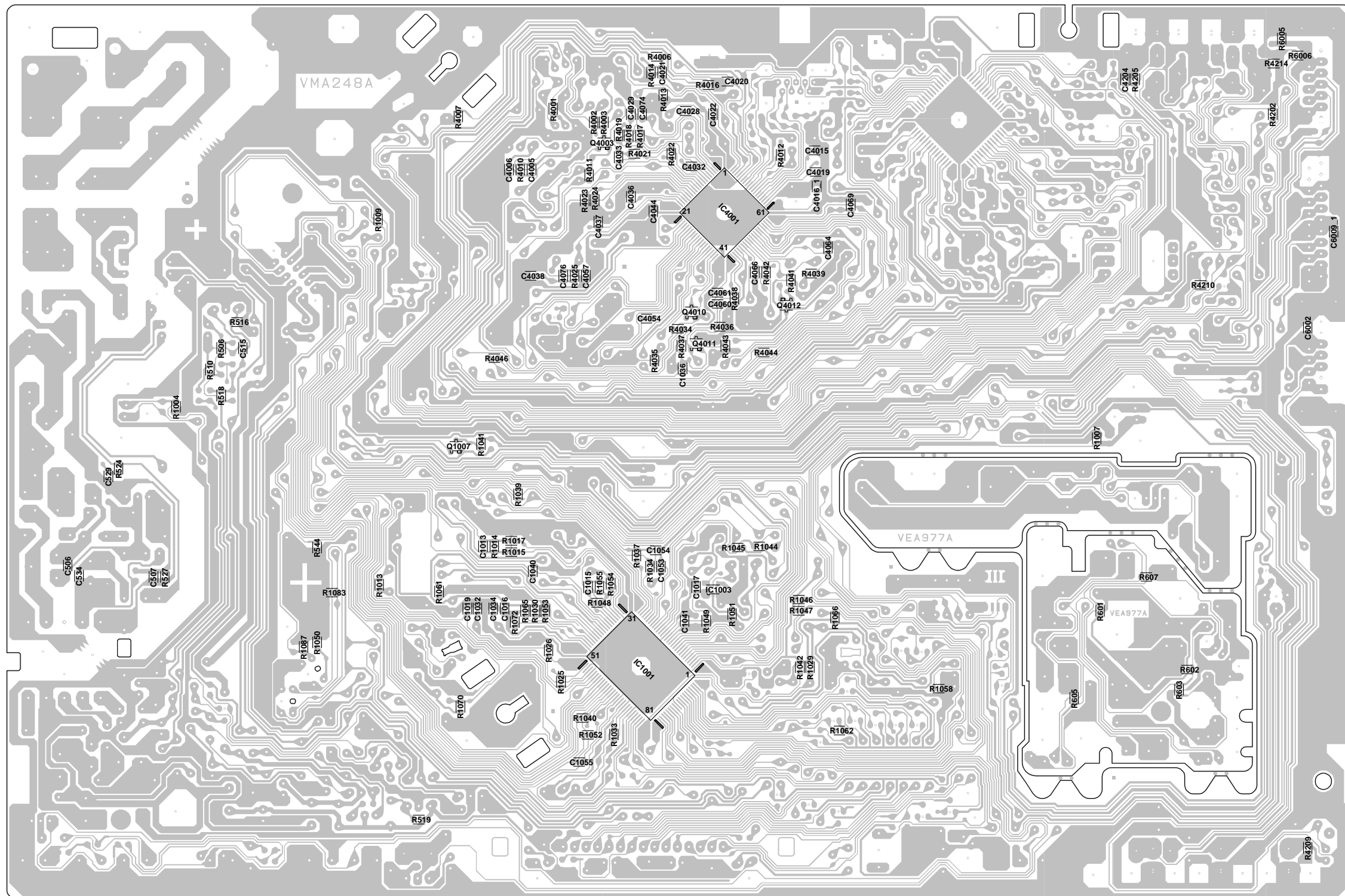

Y/C/AUDIO/CCD/HEAD AMP SCHEMATIC DIAGRAM (SYSCON PCB)

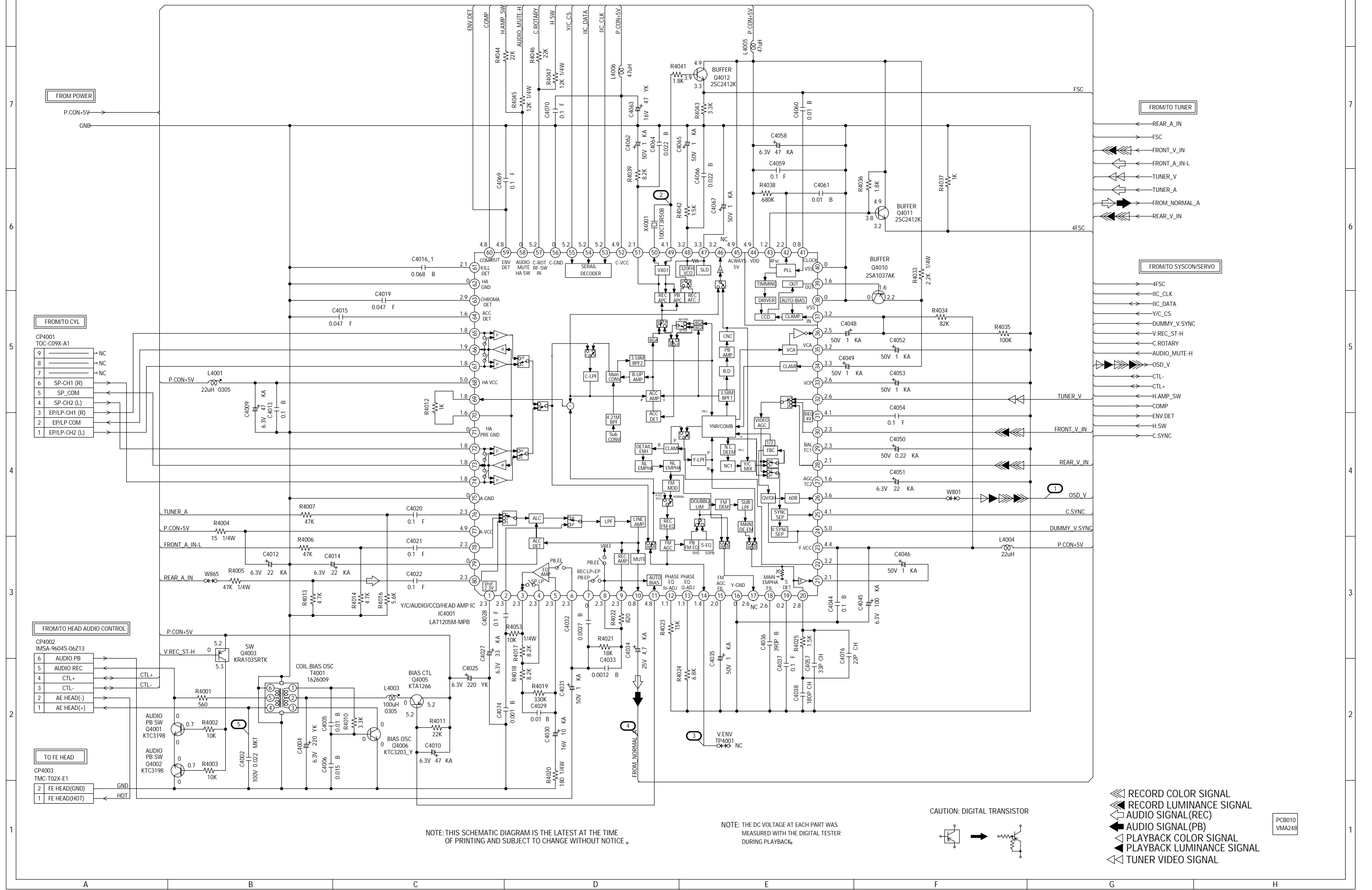

NOTE: THIS SCHEMATIC DIAGRAM IS THE LATEST AT THE TIME OF PRINTING AND SUBJECT TO CHANGE WITHOUT NOTICE .

NOTE: THE DC VOLTAGE AT EACH PART WAS MEASURED WITH THE DIGITAL TESTER DURING PLAYBACK.

CAUTION: DIGITAL TRANSISTOR

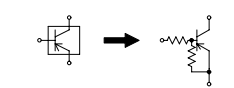

- ▶ RECORD COLOR SIGNAL
- ▶ RECORD LUMINANCE SIGNAL
- ▶ AUDIO SIGNAL (REC)
- ▶ AUDIO SIGNAL (PB)
- ▶ PLAYBACK COLOR SIGNAL
- ▶ PLAYBACK LUMINANCE SIGNAL
- ▶ TUNER VIDEO SIGNAL

PCB010
VMA248

SYSTEM CONTROL/SERVO SCHEMATIC DIAGRAM (SYSCON PCB)

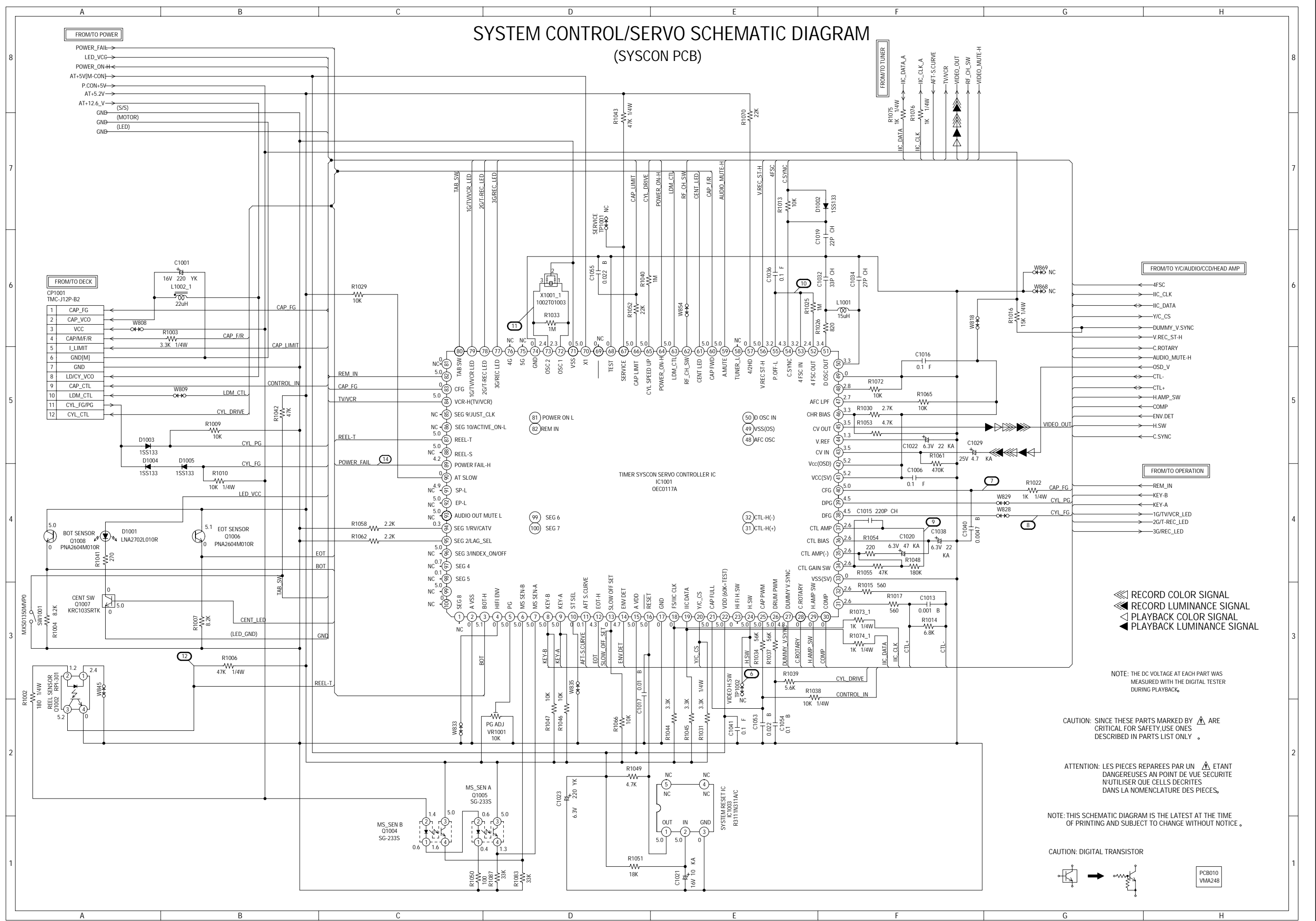

FROM/TO Y/C/AUDIO/CCD/HEAD AMP

- 4FSC
- IC_CLK
- IC_DATA
- YIC_CS
- DUMMY_V_SYNC
- V_REC_ST-H
- C_ROTARY
- AUDIO_MUTE-H
- OSD_V
- CTL-
- CTL+
- HAMP_SW
- COMP
- ENV_DET
- H_SW
- C_SYNC

FROM/TO OPERATION

- REM_IN
- KEY-B
- KEY-A
- 1G/TV/VCR_LED
- 2G/T-REC_LED
- 3G/REC_LED

- ◀ RECORD COLOR SIGNAL
- ▶ RECORD LUMINANCE SIGNAL
- ◀ PLAYBACK COLOR SIGNAL
- ▶ PLAYBACK LUMINANCE SIGNAL

NOTE: THE DC VOLTAGE AT EACH PART WAS MEASURED WITH THE DIGITAL TESTER DURING PLAYBACK.

CAUTION: SINCE THESE PARTS MARKED BY ARE CRITICAL FOR SAFETY, USE ONES DESCRIBED IN PARTS LIST ONLY.

ATTENTION: LES PIÈCES RÉPARÉES PAR UN ÉTANT DANGEREUSES AN POINT DE VUE SÉCURITÉ N'UTILISER QUE CELLES DÉCRITES DANS LA NOMENCLATURE DES PIÈCES.

NOTE: THIS SCHEMATIC DIAGRAM IS THE LATEST AT THE TIME OF PRINTING AND SUBJECT TO CHANGE WITHOUT NOTICE.

CAUTION: DIGITAL TRANSISTOR

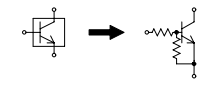

PCB010
VMA248

POWER SCHEMATIC DIAGRAM (SYSCON PCB)

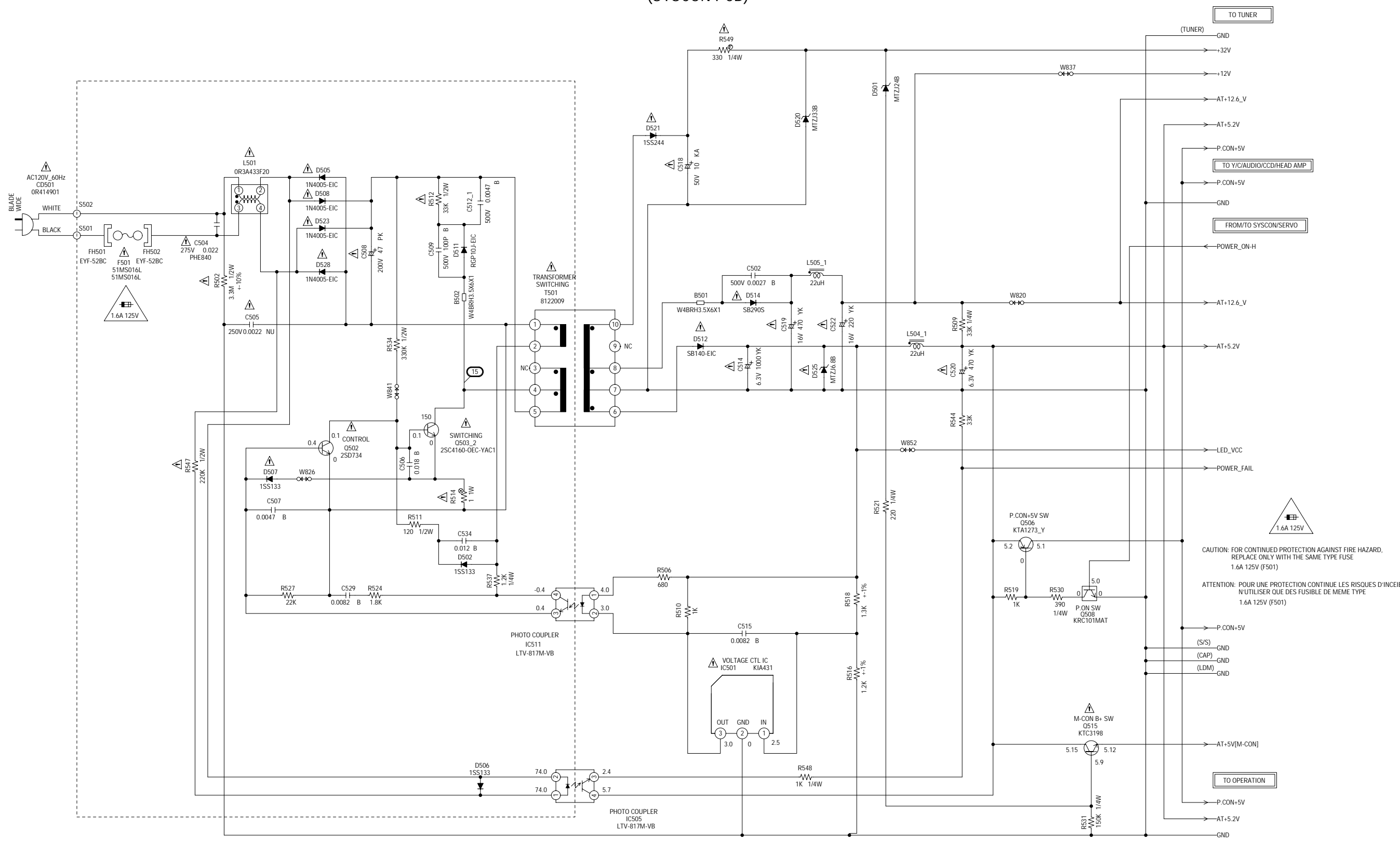

NOTE: THE DC VOLTAGE AT EACH PART WAS MEASURED WITH THE DIGITAL TESTER DURING PLAYBACK.

NOTE: THIS SCHEMATIC DIAGRAM IS THE LATEST AT THE TIME OF PRINTING AND SUBJECT TO CHANGE WITHOUT NOTICE.

ATTENTION: LES PIÈCES RÉPARÉES PAR UN ÉTANT DANGEREUSES AN POINT DE VUE SECURITE N'UTILISER QUE CELLS DÉCRITES DANS LA NOMENCLATURE DES PIÈCES.

CAUTION: SINCE THESE PARTS MARKED BY ARE CRITICAL FOR SAFETY, USE ONES DESCRIBED IN PARTS LIST ONLY.

CAUTION: DIGITAL TRANSISTOR

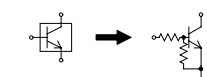

PCB010
VMA248

CAUTION: FOR CONTINUED PROTECTION AGAINST FIRE HAZARD, REPLACE ONLY WITH THE SAME TYPE FUSE 1.6A 125V (F501)
ATTENTION: POUR UNE PROTECTION CONTINUE LES RISQUES D'INCENDIE N'UTILISER QUE DES FUSIBLE DE MEME TYPE 1.6A 125V (F501)

OPERATION SCHEMATIC DIAGRAM (SYSCON PCB)

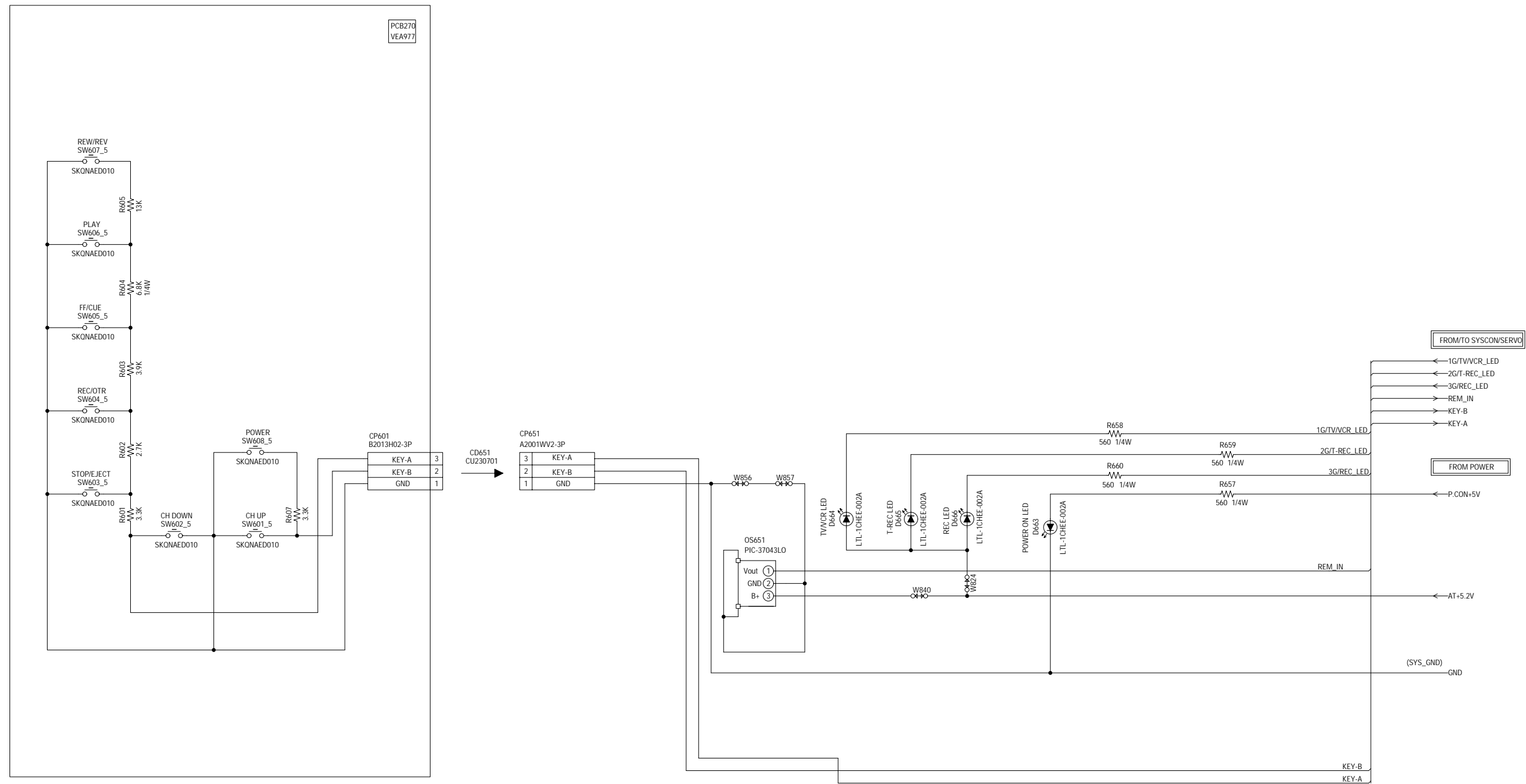

NOTE: THE DC VOLTAGE AT EACH PART WAS MEASURED WITH THE DIGITAL TESTER DURING PLAYBACK.

NOTE: THIS SCHEMATIC DIAGRAM IS THE LATEST AT THE TIME OF PRINTING AND SUBJECT TO CHANGE WITHOUT NOTICE.

TUNER SCHEMATIC DIAGRAM (SYSCON PCB)

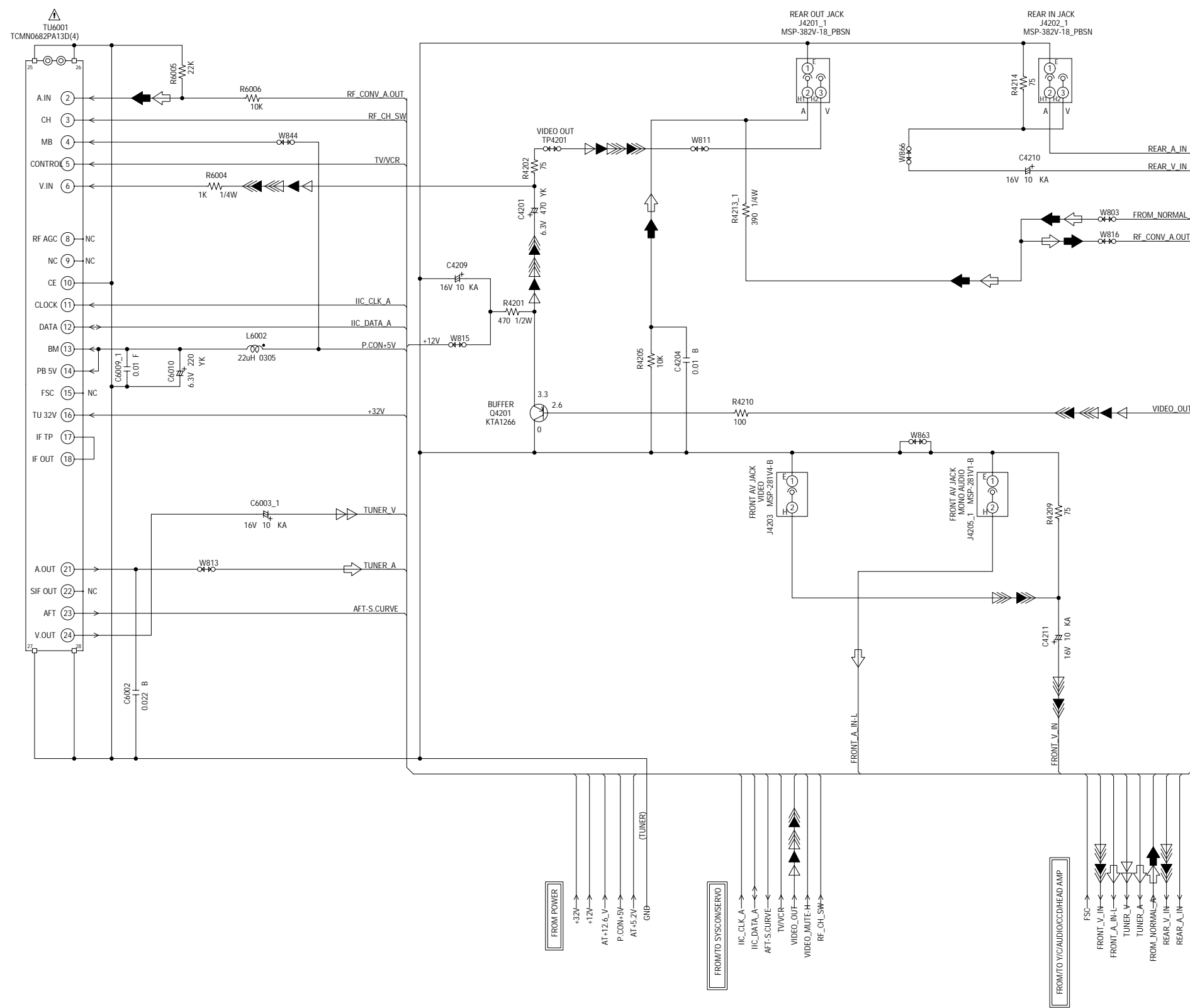

NOTE: THE DC VOLTAGE AT EACH PART WAS MEASURED WITH THE DIGITAL TESTER DURING PLAYBACK.

NOTE: THIS SCHEMATIC DIAGRAM IS THE LATEST AT THE TIME OF PRINTING AND SUBJECT TO CHANGE WITHOUT NOTICE.

CAUTION: SINCE THESE PARTS MARKED BY ARE CRITICAL FOR SAFETY, USE ONES DESCRIBED IN PARTS LIST ONLY.

ATTENTION: LES PIÈCES RÉPARÉES PAR UN ÉTANT DANGEREUSES AN POINT DE VUE SÉCURITÉ N'UTILISER QUE CELLES DÉCRITES DANS LA NOMENCLATURE DES PIÈCES.

- RECORD LUMINANCE SIGNAL
- RECORD COLOR SIGNAL
- AUDIO SIGNAL (REC)
- AUDIO SIGNAL (PB)
- TUNER VIDEO SIGNAL
- PLAYBACK LUMINANCE SIGNAL
- PLAYBACK COLOR SIGNAL

PCB010
VMA248

INTERCONNECTION DIAGRAM

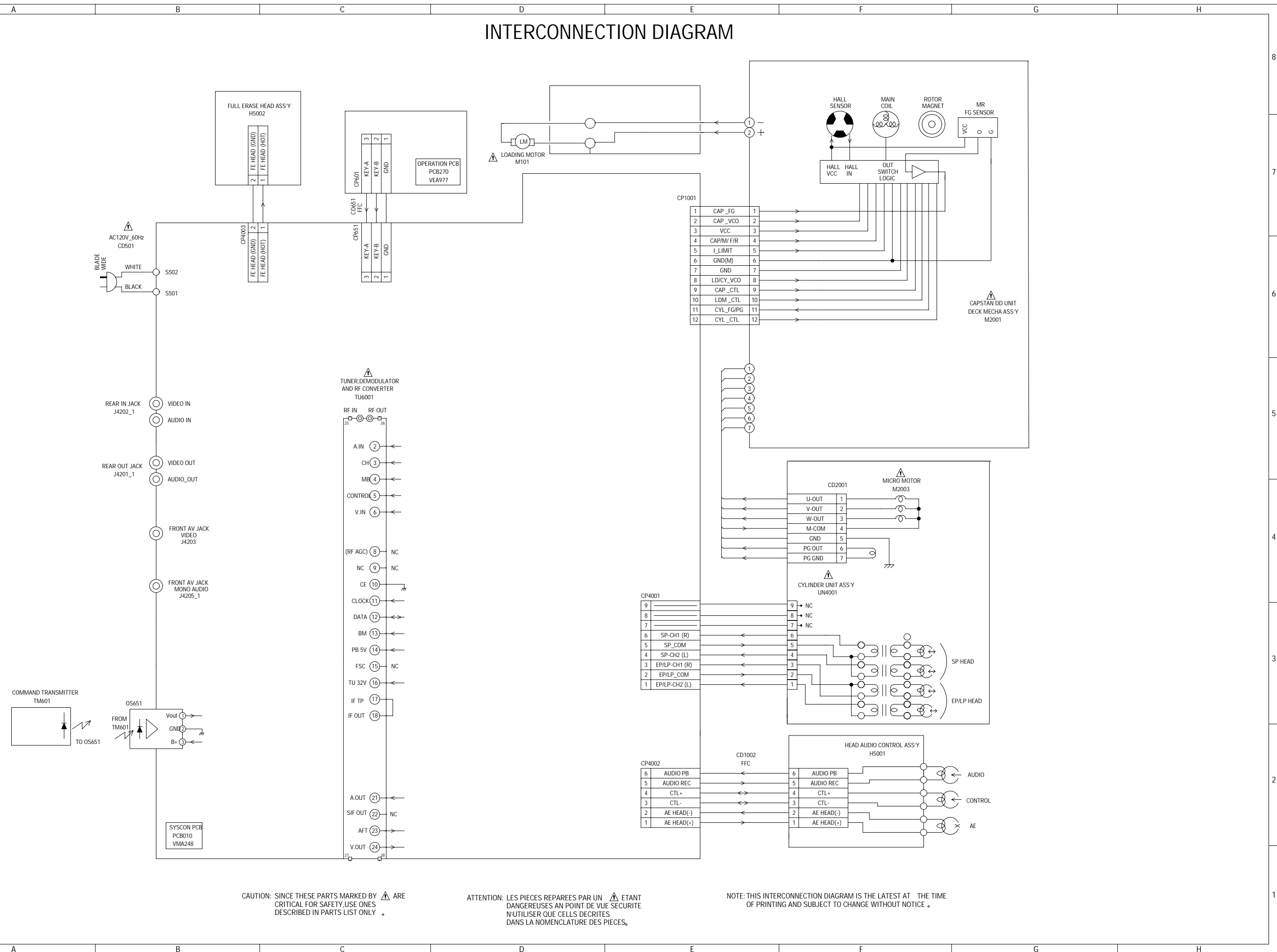

CAUTION: SINCE THESE PARTS MARKED BY ARE CRITICAL FOR SAFETY, USE ONES DESCRIBED IN PARTS LIST ONLY.

ATTENTION: LES PIÈCES RÉPARÉES PAR UN ÉTANT DANGEREUSES AN POINT DE VUE SECURITE N'UTILISER QUE CELLS DECRITES DANS LA NOMENCLATURE DES PIÈCES.

NOTE: THIS INTERCONNECTION DIAGRAM IS THE LATEST AT THE TIME OF PRINTING AND SUBJECT TO CHANGE WITHOUT NOTICE.

WAVEFORMS

Y/C/AUDIO/CCD/HEAD AMP

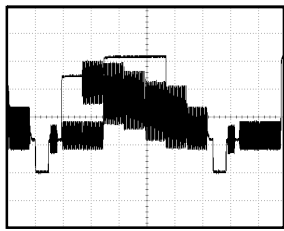

① POWER ON
10µs 500mV/div

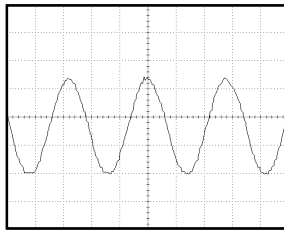

② POWER ON
100ns 100mV/div

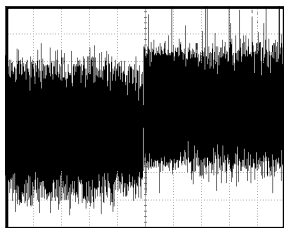

③ PB
1ms 100mV/div

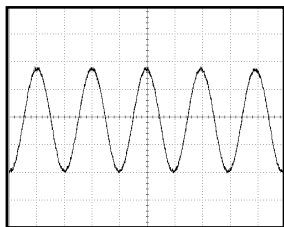

④ PB
500µs 200mV/div

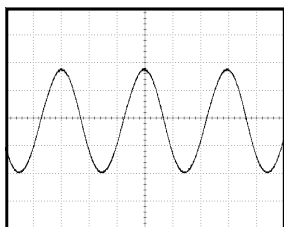

⑤ REC
5µs 20V/div

SYSCON/SERVO

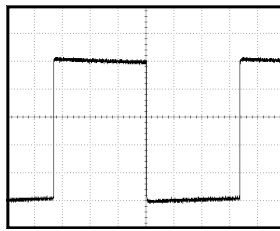

⑥ POWER ON
5ms 1.0V/div



⑦ PB
2µs 1.0V/div

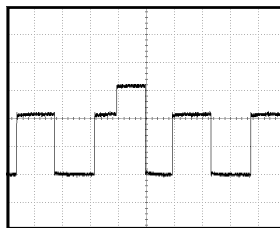

⑧ POWER ON
500µs 1.0V/div

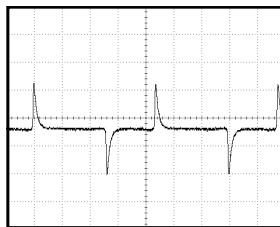

⑨ FF/REW
500µs 500mV/div

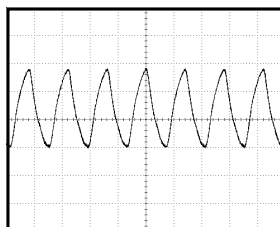

⑩ POWER ON
50ns 500mV/div

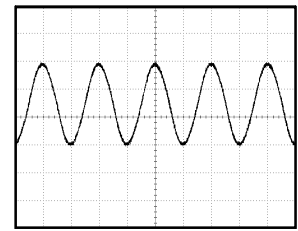

⑪ POWER ON
50ns 1.0V/div

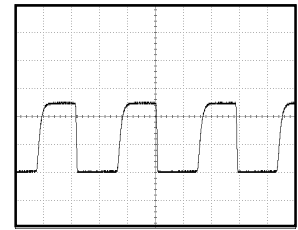

⑫ FF/REW
5ms 2V/div

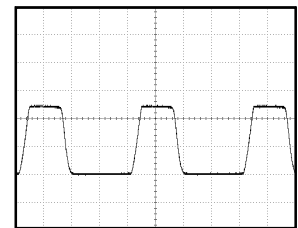

⑭ POWER OFF
5ms 2V/div

POWER

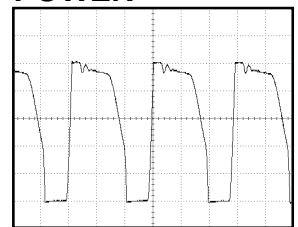

⑮ PB
2µs 50V/div

NOTE: The following waveforms were measured at the point of the corresponding balloon number in the schematic diagram.

MECHANICAL EXPLODED VIEW

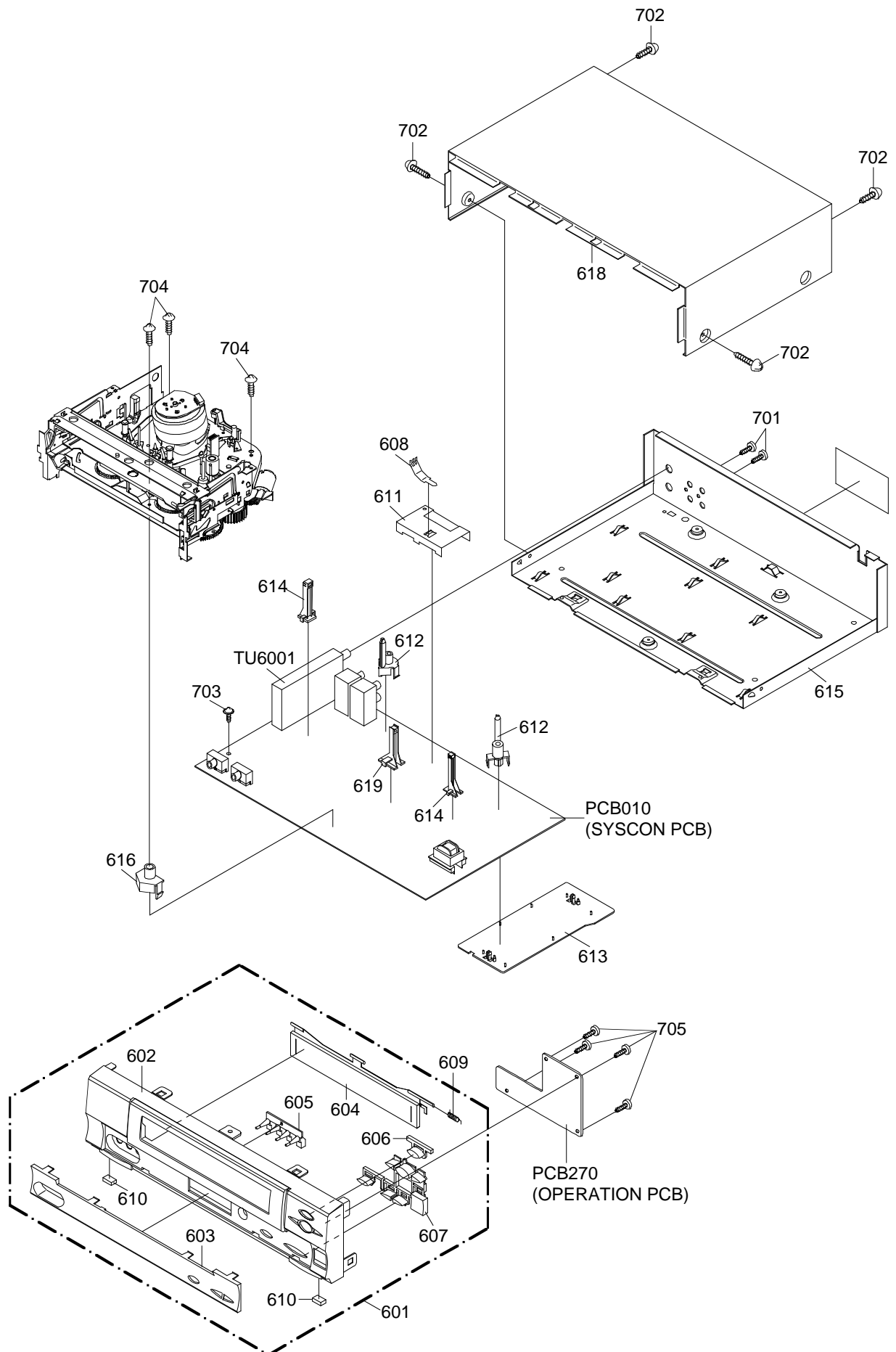

CHASSIS EXPLODED VIEW (TOP VIEW)

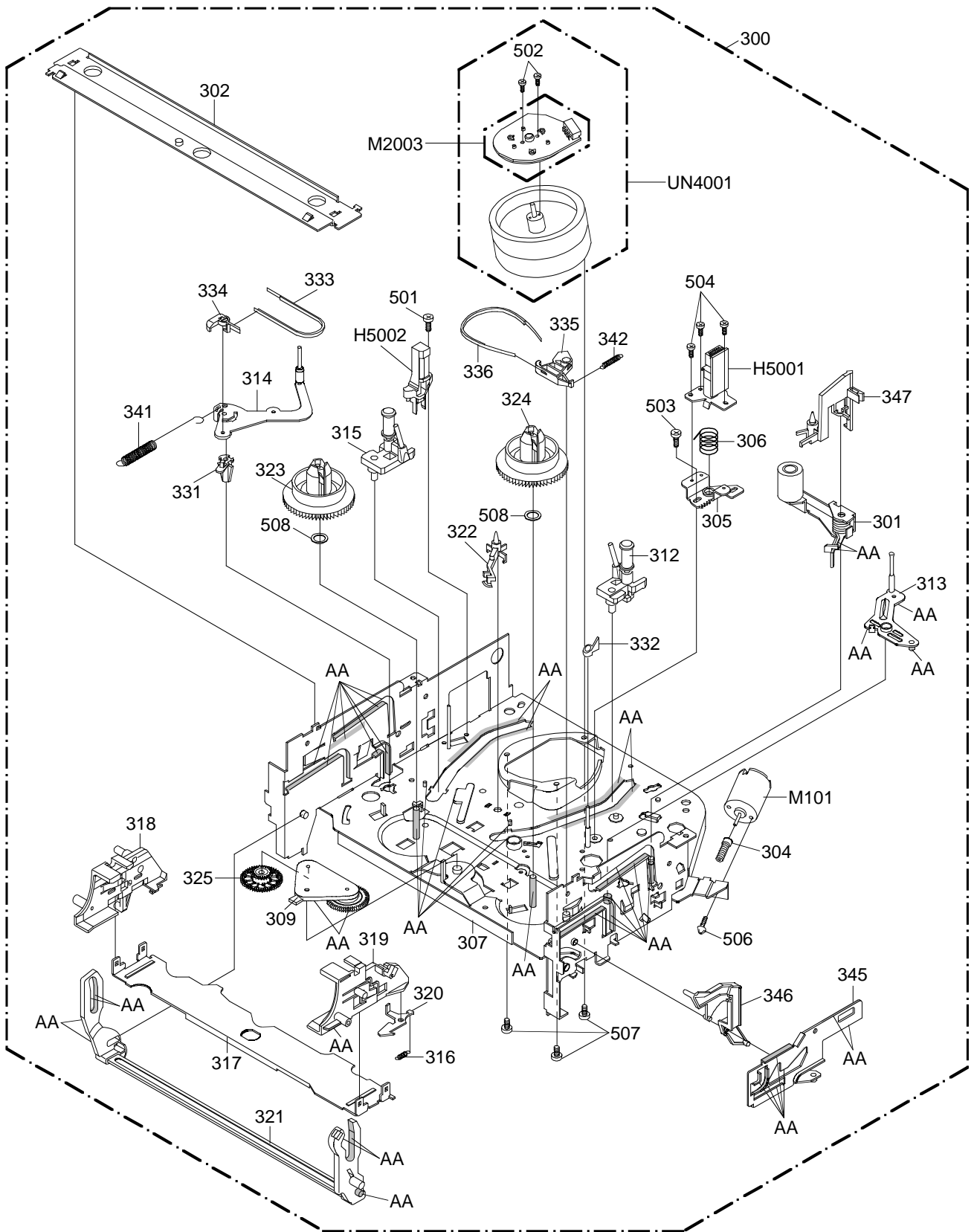

CLASS	MARK
GREASE	AA

NOTE: Applying positions AA for the grease are displayed for this section. Check if the correct grease is applied for each position.

CHASSIS EXPLODED VIEW (BOTTOM VIEW)

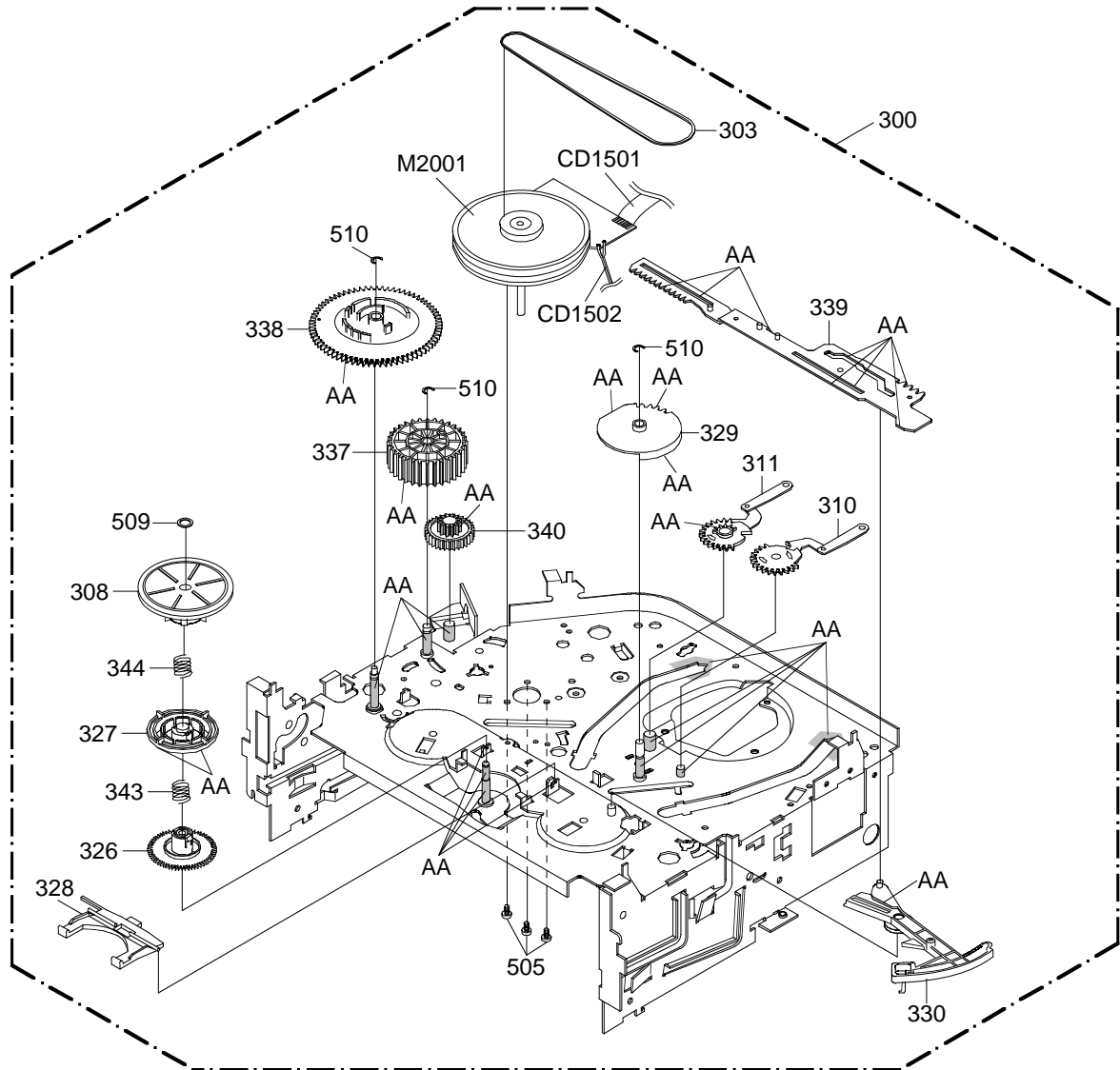

CLASS	MARK
GREASE	AA

NOTE: Applying positions AA for the grease are displayed for this section.
Check if the correct grease is applied for each position.

MECHANICAL REPLACEMENT PARTS LIST

Location No.	TSB P/N	Reference No.	Description	
601	BZ610292	A4F117B720	CABINET,FRONT ASSY	
602	BZ710567	701WPJB544	CABINET,FRONT	
603	BZ710568	711WPDA443	PLATE,DISPLAY	
604	BZ710569	712WPJB293	FLAP	
605	BZ710570	713WPAA056	GLASS,LED	
606	BZ710571	735WPJA537	BUTTON,PLAY	
607	BZ710572	735WPJA538	BUTTON,STOP/EJECT	
608	BZ710331	753WUAA006	SPRING,EARTH H/AMP	
609	BZ710010	743WKA0032	SPRING,FLAP	
610	BZ710573	800WFA0045	CUSHION,LEG	
611	BZ710466	752WSA0230	SHIELD,CASE HEAD AMP	
612	BZ710574	701WPA0680	HOLDER,DECK	
613	BZ710575	755WPA0020	PLATE,COVER POWER	
614	BZ710178	85OP700036	HOLDER,EOT SENSOR	
615	BZ710576	702WSAA033	PLATE,BOTTOM	
616	BZ710577	701WPA0686	HOLDER,DECK	
618	BZ710578	702WSB0060	CABINET,TOP	
619	BZ710497	85OP700037	HOLDER,LED	
701	BZ710579	8110230804	SCREW,TAP TITE(P) BIND	3x8
702	BZ710580	8109230802	SCREW,TAP TITE(B)	3x8
703	BZ710581	8109230704	SCREW,TAP TITE(B) R BIND	3x7
704	BZ710582	8109130B94	SCREW,TAP TITE(B) R PAN	3x29
705	BZ710187	8110226804	SCREW,TAP TITE(P) BIND	2.6x8
---	BZ710583	792WHAA057	PACKAGE	
---	BZ710584	793WCDB126	GIFT BOX	
---	BZ614354	J4F11701	INSTRUCTION BOOK	

CHASSIS REPLACEMENT PARTS LIST

Location No.	TSB P/N	Reference No.	Description
300	BZ610293	A4F117B420K	DECK ASSY
301	BZ710564	85OA400234	PINCH ROLLER BLOCK
302	BZ710514	85OP900746	BRACKET,TOP 3V
303	BZ710193	85OP200290	BELT,CAPSTAN (S)
304	BZ710515	85OP600581	WORM
305	BZ710094	85OP500083	BASE,AC HEAD
306	BZ710112	85OP800324	SPRING,AC HEAD
307	BZ710516	85OA000459	MAIN CHASSIS ASS'Y
308	BZ710517	85OA200089	CLUTCH ASS'Y
309	BZ710518	85OA200090	ARM IDLER ASS'Y
310	BZ710519	85OA300065	LOADING ARM S UNIT
311	BZ710520	85OA300066	LOADING ARM T UNIT
312	BZ710521	85OA400223	INCLINED BASE T UNIT 3S
313	BZ710522	85OA400232	P5 ARM ASS'Y 2
314	BZ710523	85OA400233	TENSION ARM ASS'Y (WT)
315	BZ710524	85OA400231	INCLINED BASE S UNIT
316	BZ710525	85OP800358	SPRING,LOCKER
317	BZ710526	85OP900736	CASS,HOLDER
318	BZ710527	85OP900748	CASS,SIDE L
319	BZ710528	85OP900749	CASS,SIDE R
320	BZ710529	85OP900739	LOCKER,R
321	BZ710530	85OA900228	LINK UNIT
322	BZ710531	85OP000496	POST,CASS GUIDE
323	BZ710532	85OP200316	REEL,S (S)
324	BZ710533	85OP200317	REEL,T (S)
325	BZ710534	85OP200308	GEAR,IDLER
326	BZ710535	85OP200311	GEAR,CLUTCH
327	BZ710536	85OP200312	GEAR,COUPLING
328	BZ710537	85OP200313	LEVER,CLUTCH
329	BZ710538	85OP300194	GEAR,MAIN LOADING
330	BZ710092	85OP400490	LEVER,TENSION
331	BZ710093	85OP400492	HOLDER,TENSION
332	BZ710366	85OP400520	CAP.P4
333	BZ710539	85OP400539	BAND,TENSION
334	BZ710540	85OP400533	CONNECT,TENSION
335	BZ710541	85OP600573	ARM,BRAKE T
336	BZ710542	85OP600583	BAND,BRAKE T
337	BZ710543	85OP600577	CAM,PINCH ROLLER
338	BZ710544	85OP600578	CAM,MAIN
339	BZ710545	85OP600579	ROD,MAIN
340	BZ710546	85OP600582	GEAR,JOINT
341	BZ710110	85OP800322	SPRING,TENSION
342	BZ710547	85OP800360	SPRING,BRAKE T
343	BZ710548	85OP800355	SPRING,COUPLING
344	BZ710549	85OP800356	SPRING,RING
345	BZ710565	85OP900750	LEVER,LINK 2
346	BZ710551	85OP900744	LEVER,FLAP
347	BZ710552	85OP900745	CASS,OPENER

CHASSIS REPLACEMENT PARTS LIST

Location No.	TSB P/N	Reference No.	Description	
501	BZ710049	8107226804	SCREW,TAP TITE(S) BIND	2.6x8
502	BZ710390	8107226504	SCREW,TAP TITE(S) BIND	2.6x5
503	BZ710371	8107226404	SCREW,TAP TITE(S) BIND	2.6x4
504	BZ710046	8102120604	SCREW,PAN	M2x6
505	BZ710050	8109126604	SCREW,TAP TITE(B) PAN	2.6x6
506	BZ710553	810A130404	SCREW/WASHER(A)	M3x4
507	BZ710219	810A126504	SCREW/WASHER(A)	M2.6x5
508	BZ710056	82Q264713N	POLYSLIDER WASHER	2.6x4.7xT0.13
509	BZ710054	82P184505N	POLYSLIDER WASHER(CUT)	1.8x4.5xT0.5
510	BZ710058	83ETW30000	E-RING	3.0
CD1501	BZ614338	122H071603	CORD JUMPER	SMCD-7X151
CD1502	BZ614339	122Y021902	CORD JUMPER	2Y021902
H5001	BZ710040	1523D91034	HEAD (AUDIO CONTROL)	HVMXA1072A
H5002	BZ710041	1543D02013	HEAD (FULL ERASE)	HVFHP0032A
△ M101	BZ710566	1596P98001	MOTOR (LOADING)	MXN13FB12K3
△ M2001	BZ710555	1510S98036	CAPSTAN DD UNIT	F2QVB08
△ M2003	BZ710391	1589S11015	MICRO MOTOR	I2OAL01
△ UN4001	BZ610294	A4F114B500	CYLINDER UNIT ASS'Y	A4F114B500

ELECTRICAL REPLACEMENT PARTS LIST

Location No.	TSB P/N	Reference No.	Description
RESISTORS			
△R502	BZ210219	R0G3K2335K	RC 3.3M OHM 1/2W
△R512	BZ210038	R002T2333J	RC 33K OHM 1/2W
△R514	BZ210039	R3X181010J	R,METAL OXIDE 1 OHM 1W
△R547	BZ210220	R002T2224J	RC 220K OHM 1/2W
△R549	BZ210221	R65584331J	R,FUSE 330 OHM 1/4W
CAPACITORS			
△C504	BZ210222	P2472B223M	CMP 0.022 UF 275V PHE840
△C505	BZ110185	CBLLYEMH3M	CC 0.0022UF 250V
△C508	BZ110186	E62QFC470M	CE 47 UF 200V
△C514	BZ110187	E02LT0102M	CE 1000 UF 6.3V
△C518	BZ110188	E50HU5100M	CE 10 UF 50V
△C519	BZ110081	E02LT2471M	CE 470 UF 16V
△C520	BZ110189	E02LU0471M	CE 470 UF 6.3V
△C522	BZ110190	E02LU2221M	CE 220 UF 16V
DIODES			
D501	BZ410102	D97U02401B	DIODE,ZENER MTZJ24B T-77
D502	BZ410006	D1VT001330	DIODE,SILICON 1SS133T-77
△D505	BZ410085	D2WYN40050	DIODE,SILICON 1N4005-EIC
D506	BZ410006	D1VT001330	DIODE,SILICON 1SS133T-77
△D507	BZ410006	D1VT001330	DIODE,SILICON 1SS133T-77
△D508	BZ410085	D2WYN40050	DIODE,SILICON 1N4005-EIC
D511	BZ410103	D2WXGP10J0	DIODE,RECTIFIER RGP10J-EIC
△D512	BZ410077	D2WXS1400	DIODE,SCHOTTKY SB140-EIC
△D514	BZ410076	D2WXB290S0	DIODE,SILICON SB290S
D520	BZ410037	D97U03301B	DIODE,ZENER MTZJ33B T-77
△D521	BZ410030	D17T002440	DIODE,SILICON 1SS244T-77
△D523	BZ410085	D2WYN40050	DIODE,SILICON 1N4005-EIC
△D525	BZ410022	D97U06R81B	DIODE,ZENER MTZJ6.8B T-77
△D528	BZ410085	D2WYN40050	DIODE,SILICON 1N4005-EIC
D663	BZ410087	0021E2Q140	LED LTL-1CHEE-002A
D664	BZ410087	0021E2Q140	LED LTL-1CHEE-002A
D665	BZ410087	0021E2Q140	LED LTL-1CHEE-002A
D666	BZ410087	0021E2Q140	LED LTL-1CHEE-002A
D1001	BZ410095	0010100320	INFRARED LED LNA2702L010R
D1002	BZ410006	D1VT001330	DIODE,SILICON 1SS133T-77
D1003	BZ410006	D1VT001330	DIODE,SILICON 1SS133T-77
D1004	BZ410006	D1VT001330	DIODE,SILICON 1SS133T-77
D1005	BZ410006	D1VT001330	DIODE,SILICON 1SS133T-77
ICS			
△IC501	BZ611019	I1KJ9A4310	IC KIA431
IC505	BZ410088	0002E00610	PHOTO COUPLER LTV-817M-VB
IC511	BZ410088	0002E00610	PHOTO COUPLER LTV-817M-VB
IC1001	BZ611094	I54F50117A	IC OEC0117A
IC1003	BZ611057	IC7J0311A0	IC R3111N311A/C-TR
IC4001	BZ611095	I03F3205M0	IC LA71205M-MPB
TRANSISTORS			
△Q502	BZ510031	TD3T007340	TRANSISTOR,SILICON 2SD734(E,F)-AA
△Q503	BZ510015	TCWQ4160E0	TRANSISTOR,SILICON 2SC4160-OEC-YAC1
Q506	BZ611094	TAAT01273Y	TRANSISTOR,SILICON KTA1273_Y
Q508	BZ611095	TNATA03002	COMPOUND TRANSISTOR KRC101MAT
△Q515	BZ510069	TCATC31980	TRANSISTOR,SILICON KTC3198-AT(Y,GR)
Q1002	BZ410049	0002700590	PHOTO COUPLER RPI-301
Q1004	BZ410104	0002M00580	PHOTO COUPLER SG-233S
Q1005	BZ410104	0002M00580	PHOTO COUPLER SG-233S
Q1006	BZ410042	0000100380	PHOTO TRANSISTOR PNA2604M010R
Q1007	BZ510067	TNAAC05002	COMPOUND TRANSISTOR KRC103SR TK
Q1008	BZ410042	0000100380	PHOTO TRANSISTOR PNA2604M010R
Q4001	BZ510069	TCATC31980	TRANSISTOR,SILICON KTC3198-AT(Y,GR)
Q4002	BZ510069	TCATC31980	TRANSISTOR,SILICON KTC3198-AT(Y,GR)
Q4003	BZ510072	TPAAC05002	COMPOUND TRANSISTOR KRA103SR TK
Q4005	BZ510073	TAATA12660	TRANSISTOR,SILICON KTA1266-AT(Y,GR)
Q4006	BZ510070	TCAT032034	TRANSISTOR,SILICON KTC3203_Y-AT
Q4010	BZ510001	T6YJ1037K0	TRANSISTOR,SILICON 2SA1037AKT146R,S
Q4011	BZ510002	T8YJ2412K0	TRANSISTOR,SILICON 2SC2412KT146 R,S
Q4012	BZ510002	T8YJ2412K0	TRANSISTOR,SILICON 2SC2412KT146 R,S
Q4201	BZ510073	TAATA12660	TRANSISTOR,SILICON KTA1266-AT(Y,GR)
COILS & TRANSFORMERS			
△L501	BZ310036	029T000083	COIL,LINE FILTER 0R3A433F20
L504	BZ310091	021W7A220K	COIL 22 UH
L505	BZ310091	021W7A220K	COIL 22 UH
L1001	BZ310161	0216A6150K	COIL 15 UH
L1002	BZ310091	021W7A220K	COIL 22 UH
L4001	BZ310039	02167F220J	COIL 22 UH
L4003	BZ310041	02167F101J	COIL 100 UH
L4004	BZ310162	0216A6220K	COIL 22 UH
L4005	BZ310007	0216A6470K	COIL 47 UH
L4006	BZ310007	0216A6470K	COIL 47 UH

ELECTRICAL REPLACEMENT PARTS LIST

Location No.	TSB P/N	Reference No.	Description
COILS & TRANSFORMERS			
L6002	BZ310039	02167F220J	COIL 22 UH
▲ T501	BZ310163	0481220094	TRANSFORMER, SWITCHING 8122009
T4001	BZ310114	031626009R	COIL, BIAS OSC 1626009
JACKS			
J4201	BZ614344	060J401078	RCA JACK MSP-382V-18_PBSN
J4202	BZ614344	060J401078	RCA JACK MSP-382V-18_PBSN
J4203	BZ614345	060J401079	RCA JACK MSP-281V4-B
J4205	BZ614346	060J401080	RCA JACK MSP-281V1-B
SWITCHES			
SW601	BZ612005	0504201T32	SWITCH, TACT SKQNAED010
SW602	BZ612005	0504201T32	SWITCH, TACT SKQNAED010
SW603	BZ612005	0504201T32	SWITCH, TACT SKQNAED010
SW604	BZ612005	0504201T32	SWITCH, TACT SKQNAED010
SW605	BZ612005	0504201T32	SWITCH, TACT SKQNAED010
SW606	BZ612005	0504201T32	SWITCH, TACT SKQNAED010
SW607	BZ612005	0504201T32	SWITCH, TACT SKQNAED010
SW608	BZ612005	0504201T32	SWITCH, TACT SKQNAED010
SW1001	BZ612015	0508A11001	SWITCH(LEAF) MXS01350MVP0
VARIABLE RESISTORS			
VR1001	BZ210067	V116314BTC	VOLUME, SEMI FIXED EVNCYAA03B14
P.C. BOARD ASSEMBLIES			
PCB010	BZ610295	A4F117B010	PCB ASS'Y VMA248A
PCB270	BZ610296	A4F117B270	PCB ASS'Y VEA977A
MISCELLANEOUS			
B501	BZ310130	024HT03564	CORE, BEADS W4BRH3.5X6X1
B502	BZ310130	024HT03564	CORE, BEADS W4BRH3.5X6X1
▲ CD501	BZ614347	120R414901	CORD, AC BUSH 0R414901
CD651	BZ614348	06CU230701	CORD, JUMPER CU230701
CP601	BZ614349	067U003029	WIRE HOLDER B2013H02-3P
CP651	BZ614350	069S230629	CONNECTOR PCB SIDE A2001WV2-3P
CD6002	BZ614085	06CQL02006	CABLE SI-C108-40
CP1001	BZ614289	06972C0010	CONNECTOR PCB SIDE TMC-J12P-B2
CP4001	BZ614011	0697290620	CONNECTOR PCB SIDE TOC-C09X-A1
CP4002	BZ614087	069J760019	CONNECTOR PCB SIDE IMSA-9604S-06Z13
CP4003	BZ614009	0697120320	CONNECTOR PCB SIDE TMC-T02X-E1
▲ F501	BZ614351	081PC1R605	FUSE 51MS016L
FH501	BZ614005	06710T0006	HOLDER, FUSE EYF-52BC
FH502	BZ614005	06710T0006	HOLDER, FUSE EYF-52BC
OS651	BZ614352	077Q037001	REMOTE RECEIVER PIC-37043LO
TM601	BZ614353	076N0EA060	TRANSMITTER RC-EA060
▲ TU6001	BZ610291	0162K00027	RF UNIT TCMN0682PA13D(4)
X1001	BZ613029	1002T01003	CERAMIC OSCILLATOR CSTS1000MG96004-T2
X4001	BZ613023	100CT3R508	CRYSTAL HC-49/U
RESISTOR			
	RC.....	CARBON RESISTOR	
CAPACITORS			
	CC.....	CERAMIC CAPACITOR	
	CE.....	ALUMI ELECTROLYTIC CAPACITOR	
	CP.....	POLYESTER CAPACITOR	
	CPP.....	POLYPROPYLENE CAPACITOR	
	CPL.....	PLASTIC CAPACITOR	
	CMP.....	METAL POLYESTER CAPACITOR	
	CMPL.....	METAL PLASTIC CAPACITOR	
	CMPP.....	METAL POLYPROPYLENE CAPACITOR	

TOSHIBA VIDEO PRODUCTS PTE. LTD.

438B ALEXANDRA ROAD, BLOCK B #06-01 ALEXANDRA TECHNOPARK SINGAPORE 119968